

The **Greenstar** gas-fired condensing wall mounted combi boiler range

Technical and specification information



**INTELLIGENT
CONTROLS**
NOW
AVAILABLE
ON SI



Worcester, Bosch Group
Technical Help line

Worcester and you. Making a difference.

Working together for many years, heating professionals and Worcester have been making a real difference in hundreds of thousands of homes across the UK. We are recognised as a market leader in high efficiency, condensing boiler technology and are also committed to providing renewable energy solutions.

As part of the Bosch Group, our products are designed and manufactured to provide the high levels of quality and reliability which are synonymous with the Bosch name throughout the world.



We're a leading British company, employing more than 1,800 people at our headquarters and manufacturing plants in Worcester and at Clay Cross in Derbyshire, including a nationwide network of over 300 Service Engineers and over 80 technically-trained Field Sales Managers.

As part of Europe's largest supplier of heating products, Worcester, Bosch Group has the UK-based resources and support capability to offer you the value-added solutions we feel you deserve.

"At Worcester we recognise the vital role you, our customer, has in the specification and installation of 'A' rated, energy efficient appliances in homes across the UK. We will continue to invest in our products, people, facilities and added value services such as training, to give you the support you require in providing a total solution for your customers' comfort."

Richard Soper,
Managing Director, Worcester, Bosch Group

Contents

Page

The Greenstar condensing combi boiler range	4 - 5
The features of the Greenstar condensing combi boiler range	6 - 7
Optional plug-in controls	8 - 11
The inside story – Greenstar i Junior	12
Greenstar i Junior technical data	13
The inside story – Greenstar Si	14
Greenstar Si technical data	15
The inside story – Greenstar CDi	16
Greenstar CDi technical data	17
Installing the Greenstar combi range	18 - 27
Greenstar combi boiler range horizontal fluing options	28 - 31
Greenstar combi boiler range vertical fluing options	32 - 34
Greenstar combi boiler range plume management system options	35 - 37
Installation requirements	38 - 41
Greenstar combi boiler range accessories	42 - 45
Worcester training	46 - 47
After-sales	48



The Greenstar condensing combi boiler range



The Greenstar combi range is part of a market leading range of energy-saving condensing wall mounted gas-fired boilers.

Worcester also offers 2 floor standing gas combi boilers – the Highflow 440CDi and Highflow 550CDi. For further details on these boilers see separate Tech & Spec, part no. 8 716 106 250.

Higher efficiency therefore highly cost effective

The Greenstar condensing combi boilers have an annual efficiency (SEDBUK value) of over 90%, efficiently producing heat for your heating and/or hot water system. Non-condensing boilers achieve around 78% efficiency. Therefore, compared with a non-condensing boiler, Greenstar condensing combi boilers can cut heating and hot water bills and are cheaper to run than an older boiler.

Hence, SEDBUK Band A ratings for all models in the Greenstar condensing range.

Greenstar condensing combi boilers deliver this energy-saving performance by ingeniously recycling exhaust gases to extract and re-use the latent heat – a highly efficient use of energy which also significantly reduces carbon dioxide emissions into the atmosphere.

To all these major benefits you can add yet more: renowned Worcester quality and reliability; a range of outputs to satisfy the heating demands of a range of households; and truly exceptional all-round value for money.

Low NOx options

Worcester's commitment to reduce emissions from gas-fired condensing boilers now sees the 24i Junior, 28i Junior, 25Si and 30Si models achieve NOx values <40mg/kWh. This enables the appliances to achieve 3 credits under the Code for Sustainable Homes whilst still achieving a SEDBUK A rating.

The Greenstar combi range at a glance

	24i Junior	28i Junior	25Si	30Si	27CDi	30CDi	37CDi	42CDi
Output kW to DHW	Min	7.2kW	7.2kW	7.2kW	7.2kW	7.7kW	7.7kW	9.4kW
	Max	24kW	28kW	25kW	30kW	27kW	32kW	42kW
Flow rate at 35°C Δ T	9.8l/min	11.4l/min	10.2l/min	12.3l/min	11.1l/min	13.1l/min	15.2l/min	17.2l/min
Output kW to central heating (CH)	Min	7.2kW	7.2kW	7.2kW	7.2kW	7.7kW	7.7kW	9.4kW
	Max	24kW	24kW	24kW	24kW	26.2kW	30kW	30kW
Maximum output kW to central heating (CH) with low NOx code plug	13kW	13kW	13kW	13kW	-	-	-	-
CH temperature control	•	•	•	•	•	•	•	•
DHW temperature control	-	-	•	•	•	•	•	•
Modulating control	•	•	•	•	•	•	•	•
Natural gas	•	•	•	•	•	•	•	•
LPG boiler	•	•	•	•	•	•	•	•
Electronic ignition	•	•	•	•	•	•	•	•

The features of the Greenstar condensing combi boiler range

A condensing boiler is more efficient due to its ability to extract more heat from the flue gases normally lost to the environment through the flue system.

All Greenstar i Junior and Si combi models use the same WB3 aluminium-silicon heat cell and the Greenstar CDi model has the larger WB5 heat cell. Worcester's heat exchangers have been designed to optimise clean burning combustion over an extra large surface area. Each heat cell is factory set and 100% tested so, as long as the gas inlet pressure is correct, commissioning couldn't be any easier. The heat exchanger requires minimal servicing which means fewer spare parts during its lifetime. The heat cell can be cleaned in situ via an inspection hatch saving time during service.

As the flue gases pass through the heat exchanger this extra surface area can cool the flue gases to around 55°C whereupon the latent heat within, which would normally be lost to the atmosphere, is instead released and applied to the system.

It is this ability to extract as much heat as possible from the gas it burns that gives the Greenstar condensing combi range an exceptionally high level of operating efficiency.

This higher efficiency is recognised within Section L of the Building Regulations, subsequently achieving a higher SAP or NHER rating.

A key feature of Greenstar condensing combi boiler is the separate plate domestic hot water heat exchanger, which is guaranteed for 5 years*. This, combined with the 'keep hot' facility, ensures that hot water is delivered instantly to the tap.

Hot water mode

Whenever a hot water tap is turned on the incoming mains water will activate a flow switch which, via the electronic control system, ignites the pre-mix burner. Boiler output is automatically boosted to maximum to heat the incoming cold water as it passes through the heat exchanger. Electronic controls modulate the boiler output downwards to ensure accurate hot water temperature.

Keep hot facility

All Greenstar combi models have an in-built keep hot facility which will keep the primary water within the heat cell hot – approximately 2.5 litres volume. This will ensure that hot water is delivered instantly to the opened outlet.

Eco mode

With the Eco mode button activated, the keep hot facility is de-energised and the hot water will be heated from cold. A slight delay should be expected before the hot water is at full temperature when in the Eco mode. By selecting Eco mode less gas or LPG will be used as energy is used only on demand.

Central heating mode

On a central heating demand, the boiler will initially fire at minimum output before modulating upwards to meet the actual system requirement. Electronics within the boiler continually monitor the heating flow temperature increasing or decreasing output on demand.

Fluing options

The Greenstar combi range features 2 different sizes of multi-directional RSF flue systems, 100mm or 125mm. The flue can be run horizontally or vertically with additional 90° or 45° in-line bends allowing changes of route or direction, providing an extremely flexible and versatile fluing system enabling the appliance to be sited virtually anywhere. More details are shown on page 28.

Gas options

Greenstar combi boilers are manufactured in both natural gas and Liquid Petroleum Gas (LPG) variants.

Fascia features and control options



Greenstar i Junior fascia



Greenstar Si fascia



Greenstar CDi fascia

1. Power ON/OFF switch (Greenstar CDi model only)
2. Burner 'ON' indicator LED
3. Service mode button
4. Inspection and advanced service mode button (Greenstar CDi model only)
5. Central heating temperature control selector
6. Position for optional fascia mounted controls
7. Mains 'ON/OFF' indicator with diagnostic sequence
8. Display (Greenstar CDi model only)
9. Pressure gauge
10. Boiler reset button
11. 'Eco' mode
12. Holiday mode button (Greenstar CDi model only)
13. DHW control (Greenstar Si and CDi models only)

Energy-saving & environmental features

- SEDBUK A Rated
- Simple and intelligent control options available, optimising boiler efficiency and fuel consumption
- Low electrical consumption when the boiler is in standby mode
- Aluminium-silicon heat exchanger delivers high efficiency and reliability
- Electronic ignition
- Anti-cycle control
- Modulation control
- Condenses in DHW mode – Greenstar CDi only
- Modulating pump which uses 30% less electricity than a step pump – Greenstar CDi only

Time & labour-saving installation features

- Standard wall frame allows space for pipes behind boiler
- All models available as natural gas and LPG
- 2m mains cable pre-wired to control box – Greenstar i Junior and Si models only
- Vertical pre-piping assembly accessory – Greenstar i Junior and Si models only
- Full range of Condensfit II flue options in both 60/100mm and 80/125mm diameters. 60/100mm includes plume deflector as standard and plume management kit available as an option

End user comfort and convenience features

- 10 year guarantee on Worcester primary heat exchanger**
- Boiler protection plans available for both new and out of warranty Worcester boilers
- Bosch renowned quality and reliability
- Built-in frost protection
- Compact dimensions – Greenstar i Junior and Si models
- ECO mode for energy saving fuel consumption
- Controls behind flap – aesthetically pleasing and discourages children altering controls
- Bottom cover for boiler supplied as standard

Optional plug-in controls

There are a number of comprehensive, easy-to-use controls for Greenstar combi boilers. All fascia mounted controls offer simple plug-in connection to the boiler circuit board*.

Mechanical timers



MT10 mechanical timer (for use with all models)

The simplest Worcester control device – an easy-to-use analogue clock for setting heating time periods. It plugs into the boiler fascia via a pre-prepared plug and socket.



MT10RF mechanical RF thermostat (for use with all models)

Has an analogue display for setting comfort and economy time periods and temperature. The receiver plugs into the boiler and is activated remotely by the RF (radio frequency) controller, which requires no wiring. So installation is clean and simple – no disturbance to floorboards or carpets. Nor is there any need for a separate room thermostat.

Please note the mechanical timers do not allow control of domestic hot water pre-heat. If you wish to time the pre-heat function please use a digital timer.

Digital and wireless programmers and room thermostats



DT20RF digital RF thermostat with twin channel programmer (for use with all models)

As with the DT20, this features convenient automatic set-up and is very simple to operate. The timer plugs into the boiler and offers up to 3 different time periods a day, with the room thermostat (no separate thermostat required) providing the temperature control. This device also has all the no-wiring benefits of the MT10RF. Twin-channel function with a Greenstar condensing combi boiler times the keep hot function.



DT20 twin channel digital programmer (for use with all models)

Plugs into the boiler fascia panel and sets automatically to current time, date and day, and adjusts automatically as appropriate in line with British summer time. There are 3 separate time periods for both heating and hot water. Use either the built in pre-set programmes, or choose your own settings.

*Requires installation by a qualified engineer.



DT10RF digistat (for use with all models)

A 24-hour programmable room thermostat (which means your time settings remain the same for every day), with the ability to set different temperatures for up to 6 different time periods. No separate room thermostat is required and all the major benefits of no wiring apply. This also helps you to comply with Buildings Regulations Best Practice, as programmable room thermostats can make even further savings over more traditional room thermostats and timers.



DT10RF optimiser (for use with Greenstar Si and Greenstar CDi models only)

A sophisticated 7-day energy-saving device with the same features as the DT10RF digistat, also featuring optimum start, which calculates when it needs to fire the boiler to precisely achieve the required temperature at the required time each day. You can set different temperatures for up to 6 different time periods for each day of the week individually. As an RF (radio frequency) device it has the additional benefits of no wiring required. Nor is a separate thermostat necessary.



TD200 text display (for use with Greenstar CDi models only)

The TD200 is an advanced plug-in 7-day programmer which features automatic summer-time/winter-time changeover, and full easy-to-use text display (backlight for low light conditions) which provides more information than standard digital controls. You can set 3 on-off periods per day and the programmer's effectiveness is further enhanced by the RT10 room thermostat which gives optimum room temperature control. The digital display shows both the current and your desired (set) temperature. An advance button allows you to move on to the TD200's next heating switch point. An optional wall-mounting socket is available, enabling the TD200 to be positioned away from the boiler if required.



RT10 room thermostat (for use with Greenstar CDi models only)

A hard wired optimising room temperature controller with digital display for use with the TD200 (above). The display shows current and desired temperature and an advance button allows the user to move to the next heating switch point on the TD200.



TD200 wall mounting socket (for use with Greenstar CDi models only)

A Worcester branded wall mounting socket which allows the TD200 to be hard wired away from the boiler.

Increased SAP ratings

As well as the CDi models achieving very high SAP ratings for dwellings, the addition of the optimising temperature controller further increases these ratings as well as being part of the recommended best practice, as covered by the CHeSS design standard.



Intelligent controls



FR10 intelligent room thermostat*

The FR10 is an intelligent room thermostat that enables load compensation and will offer around 11% energy savings compared to standard on/off controls. The FR10's load compensation feature means that, rather than just switching the boiler on and off, it will adjust the flow temperature of the central heating water in line with set heating temperature requirements. The smaller the difference between the actual temperature and the set-point temperature, the lower the flow temperature from the boiler.



FR110 programmable room thermostat

The FR110 is an intelligent programmable room thermostat that enables load compensation for heating and time control of hot water systems. It works in much the same way as the FR10 but with the added benefit of built-in programming so there is no need for a separate programmer. The controller provides the choice of six weekly heating programmes, with six switching points per day. It also offers a weekly hot water programme with six switching points per day. The six switching points can be used to switch preheat on where the hot water will be delivered to the tap quickly, and energy saving economy mode where the preheat function is turned off.



FW100 weather compensation controller

The FW100 is a weather compensation controller that enables the boiler to anticipate changes in heating demand in relation to external temperatures. It comprises a programmable indoor unit to control the boiler and an external sensor located on a north facing wall. The indoor unit can be mounted on the fascia of the boiler using its simple plug-in connection, or wall-mounted remotely. The FW100 combines the functions of room thermostat and programmer and incorporates factory-set heat curves for use with radiators, underfloor heating and fan convectors, making commissioning very straightforward. The units also include a manual override for the user to boost or reduce heating if and when required.



Control option	TYPE		MOUNT		FEATURES								ELECTRICAL			BOILER TYPE			
	Mechanical	Digital	Intelligent	Fascia mounted	Wall mounted	TIME CONTROL				TEMPERATURE CONTROL				CONNECTION TYPE			COMBINATION		
						Central heating	Hot water	24 hour	7 day	Auto switch - BST/GMT	Room thermostat	Programmable room thermostat	Optimum start	Boiler flow temp compensation	Plug-in	Radio frequency	Hard wired	i Junior	Si
MT10	•			•		•								•			•	•	•
MT10RF	•				•	•					•				•		•	•	•
DT20		•		•		•			•	•				•			•	•	•
DT20RF		•			•	•			•	•				•			•	•	•
DT10RF digistat		•			•	•			•	•				•			•	•	•
DT10RF optimiser		•			•	•			•	•				•			•	•	•
TD200		•		•		•			•	•				•		•			•
RT10		•			•						•					•			•
FR10			•		•						•					•			•
FR110			•		•	•			•	•						•			•
FW100			•	•	•	•			•	•				•		•			•
ISM1			•		•									•	•				

Inside story – Greenstar i Junior condensing combi boiler series

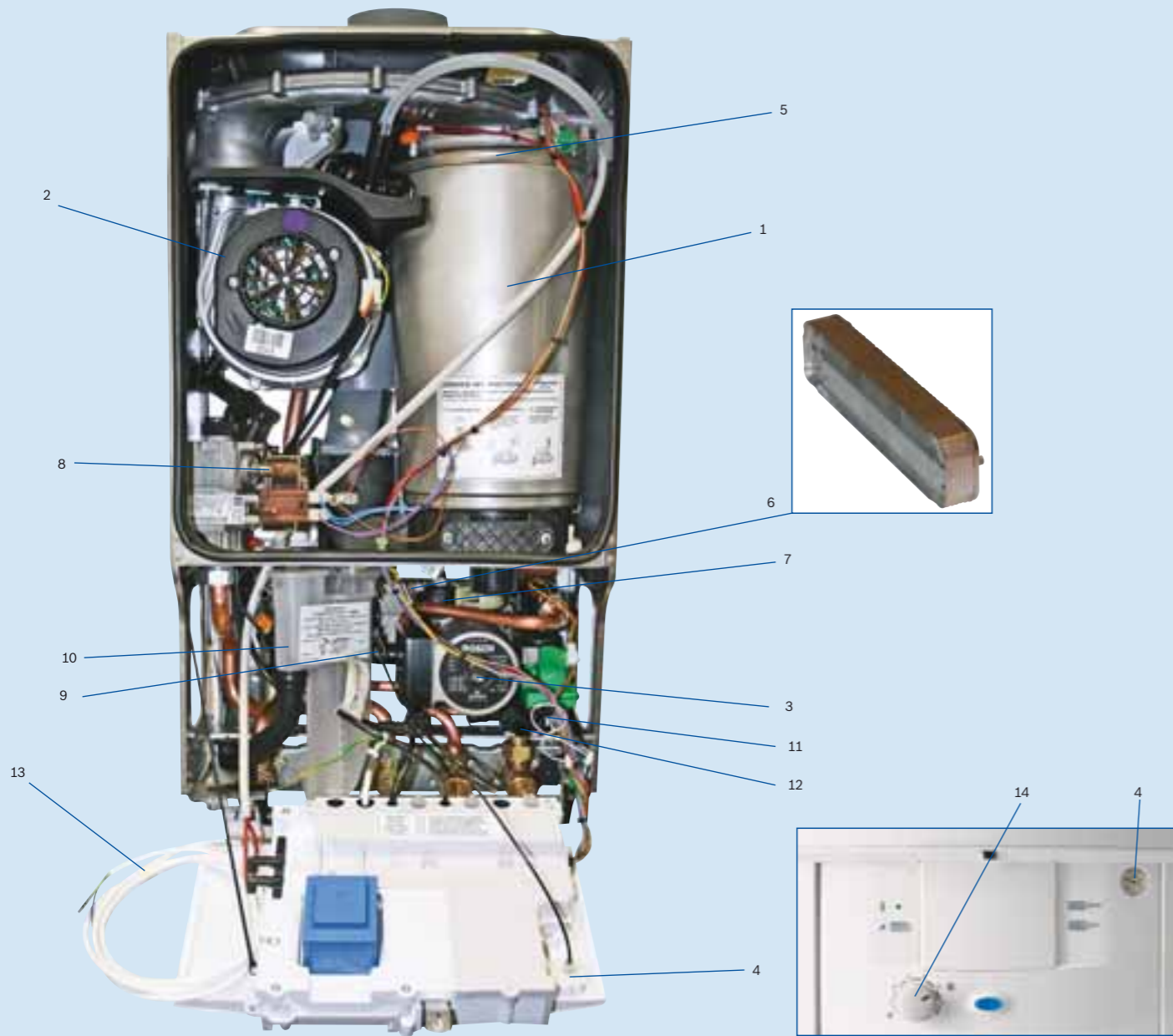

Key to components

- | | |
|---|--|
| 1. Aluminium/Silicon WB3 Heat Exchanger | 8. Gas Valve |
| 2. Pre-mix Fan | 9. Expansion Vessel Connection |
| 3. Circulating Pump | 10. Condensate Syphon |
| 4. Pressure Gauge | 11. Diverter Valve |
| 5. Down Firing Low NOx Burner | 12. Drain Point |
| 6. Plate DHW Heat Exchanger | 13. Mains Cable Pre-wired to Control Board |
| 7. Automatic Air Vent | 14. Central Heating Temperature Control |

Greenstar i Junior technical data

Model	Greenstar 24i Junior	Greenstar 28i Junior
Height (mm)	710mm (max)*	710mm (max)*
Width (mm)	400mm	400mm
Depth (mm)	330mm (max)*	330mm (max)*
Weight – lift (kg)	27.1	27.1
SEDBUK value % / band – natural gas	90.1% / Band A	90.1% / Band A
SEDBUK value % / band – LPG	91.8% / Band A	91.8% / Band A
Heating flow / return connections	22mm compression	22mm compression
Hot / cold water connections	15mm compression	15mm compression
Pressure relief valve (mm dia.)	15	15
Condensate connection	22mm plastic pipe	22mm plastic pipe
Gas connection	22mm compression	22mm compression
Primary water content (litres)	3.9	3.9
Min. domestic inlet pressure for max. DHW flow rate (bar)	1.3	1.3
Min. domestic inlet pressure to operate the appliance (bar)	0.2	0.2
Max. domestic inlet pressure (bar)	10	10
Min. flow rate to operate the appliance (l/min)	1.9	1.9
DHW flow rate @ 35°CΔT (l/min)	9.8	11.4
Output to central heating	kW (Btu/h) 7.2 - 24** (24,566 - 82,000)	kW (Btu/h) 7.2 - 24** (24,566 - 82,000)
Wall mounting jig	•	•
Filling link	• (optional)	• (optional)
Plug-in timers	• (optional)	• (optional)
Optimising room temperature controller	N/A	N/A
Max. vertical flue (mm) (100mm dia.) inc. terminal	6,400	6,400
Max. vertical flue (mm) (125mm dia.) inc. terminal	15,000	15,000
Max. horizontal flue (mm) (100mm dia.)	4,600	4,600
Max. horizontal flue (mm) (125mm dia.)	13,000	13,000
NOx classification (mg/kWh)	66	66
NOx classification with low NOx code plug (mg/kWh)	38	38
NOx class	5	5
Ingress protection (IP)	X4D	X4D

*Measured to the top or front of the curve height.
**13kW with low NOx code plug fitted.

Inside story – Greenstar Si condensing combi boiler series

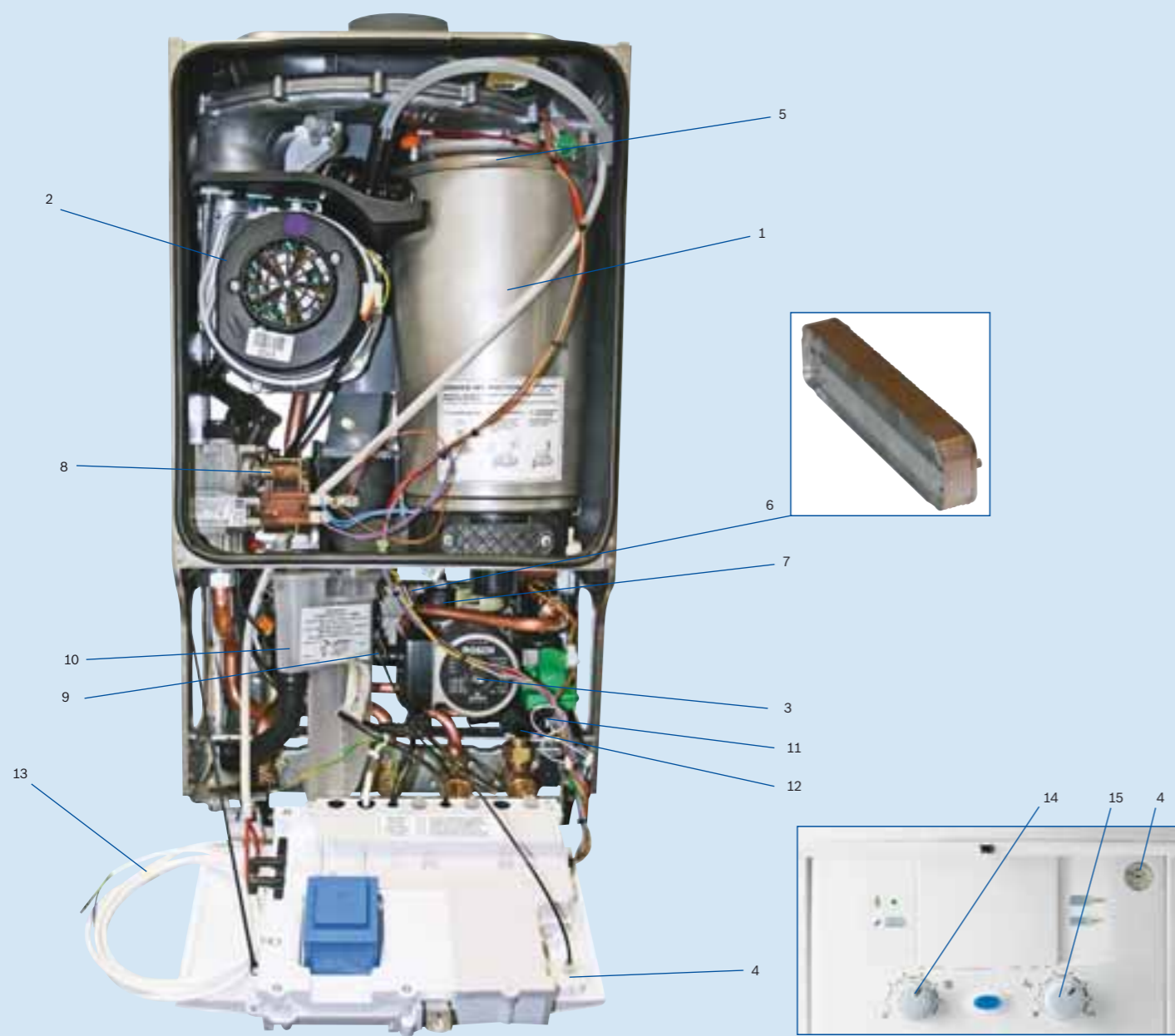

Key to components

- | | |
|---|--|
| 1. Aluminium/Silicon WB3 Heat Exchanger | 9. Expansion Vessel Connection |
| 2. Pre-mix Fan | 10. Condensate Syphon |
| 3. Circulating Pump | 11. Diverter Valve |
| 4. Pressure Gauge | 12. Drain Point |
| 5. Down Firing Low NOx Burner | 13. Mains Cable Pre-wired to Control Board |
| 6. Plate DHW Heat Exchanger | 14. Central Heating Temperature Control |
| 7. Automatic Air Vent | 15. Domestic Hot Water Temperature Control |
| 8. Gas Valve | |

Greenstar Si technical data

Model	Greenstar 25Si	Greenstar 30Si
Height (mm)	710 (max)*	710 (max)*
Width (mm)	400	400
Depth (mm)	330 (max)	330 (max)
Weight – lift (kg)	27.1	27.1
SEDBUK value % / band – natural gas	90.1% / Band A	90.1% / Band A
SEDBUK value % / band – LPG	91.8% / Band A	91.8% / Band A
Heating flow / return connections	22mm compression	22mm compression
Hot / cold water connections	15mm compression	15mm compression
Pressure relief valve (mm dia.)	15	15
Condensate connection	22mm plastic pipe	22mm plastic pipe
Gas connection	22mm compression	22mm compression
Primary water content (litres)	3.9	3.9
Min. domestic inlet pressure for max. DHW flow rate (bar)	1.3	2
Min. domestic inlet pressure to operate the appliance (bar)	0.2	0.2
Max. domestic inlet pressure (bar)	10	10
Min. flow rate to operate the appliance (l/min)	1.9	1.9
DHW flow rate @ 35°CΔT (l/min)	10.2	12.3
Output to central heating	kW (Btu/h)	kW (Btu/h)
	7.2 - 24** (24,566 - 82,000)	7.2 - 24** (24,566 - 82,000)
Wall mounting jig	•	•
Filling link	• (optional)	• (optional)
Plug-in timers	• (optional)	• (optional)
Optimising room temperature controller	• (optional)	• (optional)
Max. vertical flue (mm) (100mm dia.) inc. terminal	6,400	6,400
Max. vertical flue (mm) (125mm dia.) inc. terminal	15,000	15,000
Max. horizontal flue (mm) (100mm dia.)	4,600	4,600
Max. horizontal flue (mm) (125mm dia.)	13,000	13,000
NOx classification (mg/kWh)	66	66
NOx classification with low NOx code plug (mg/kWh)	38	38
NOx class	5	5

*Measured to the top or front of the curve height.

**13kW with low NOx code plug fitted.

Inside story – Greenstar CDi condensing combi boiler series

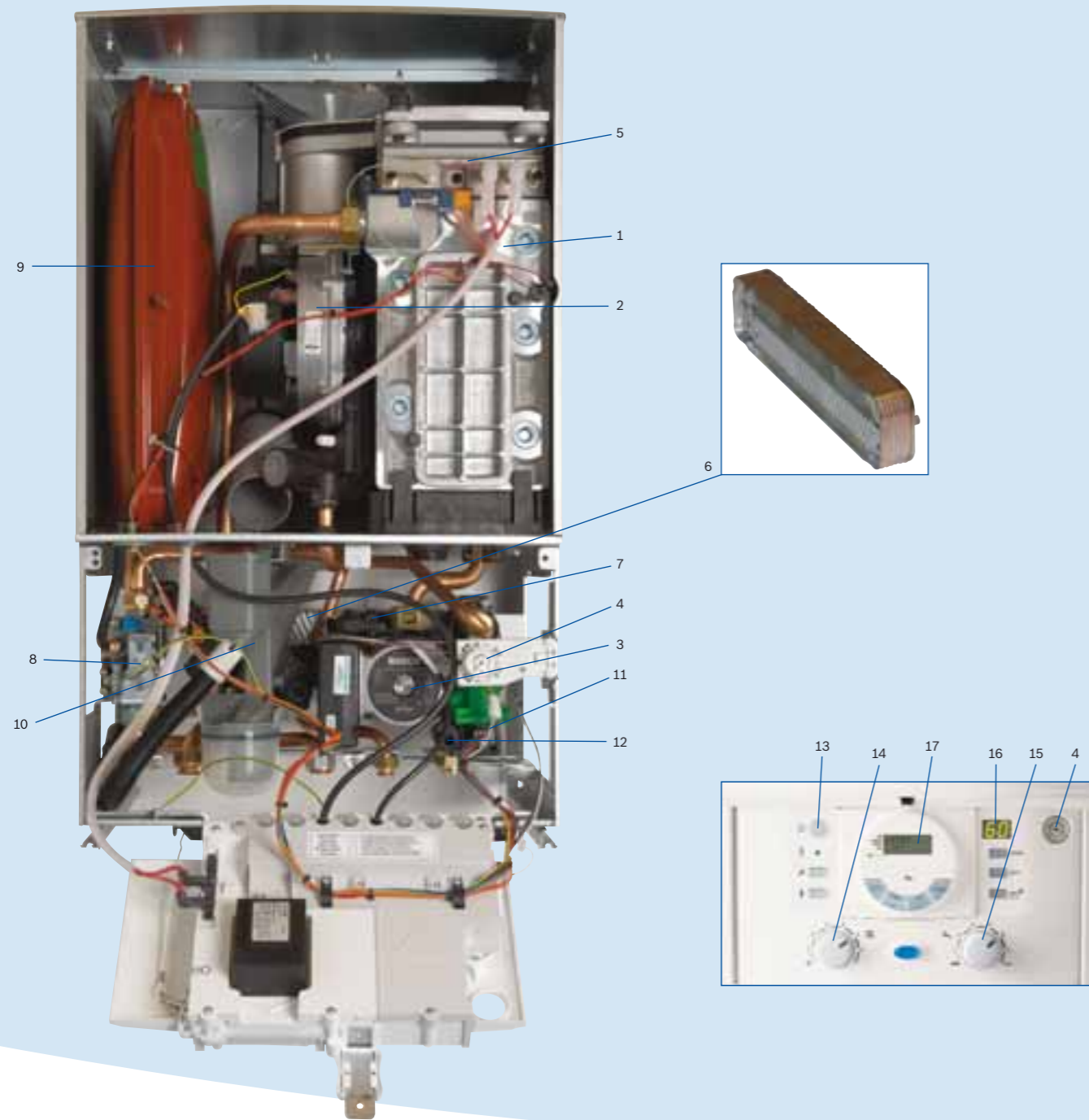

Key to components

- | | |
|---|--|
| 1. Aluminium/Silicon WB5 Heat Exchanger | 10. Condensate Syphon |
| 2. Pre-mix Fan | 11. Diverter Valve |
| 3. Modulating Pump | 12. Drain Point |
| 4. Pressure Gauge | 13. On/Off Button |
| 5. Down Firing Low NOx Burner | 14. Central Heating Temperature Control |
| 6. Plate DHW Heat Exchanger | 15. Domestic Hot Water Temperature Control |
| 7. Automatic Air Vent (hidden) | 16. Digital Display |
| 8. Gas Valve (hidden) | 17. Optional Programmer |
| 9. Expansion Vessel | |

Greenstar CDi technical data

Model	Greenstar 27CDi	Greenstar 30CDi	Greenstar 37CDi	Greenstar 42CDi
Height (mm)	760 (max)	760 (max)	760 (max)	760 (max)
Width (mm)	440	440	440	440
Depth (mm)	360 (max)	360 (max)	360 (max)	360 (max)
Weight – dry (kg)	48.5	48.5	48.5	48.5
SEDBUK value % / band – natural gas	90.2% / Band A	90.2% / Band A	90.2% / Band A	90.2% / Band A
SEDBUK value % / band – LPG	92.2% / Band A	92.2% / Band A	92.2% / Band A	92.2% / Band A
Heating flow / return connections	22mm compression	22mm compression	22mm compression	22mm compression
Hot / cold water connections	15mm compression	15mm compression	15mm compression	15mm compression
Pressure relief valve (mm dia.)	15	15	15	15
Condensate connection	22mm plastic pipe	22mm plastic pipe	22mm plastic pipe	22mm plastic pipe
Gas connection	22mm compression	22mm compression	22mm compression	22mm compression
Primary water content (litres)	3.75	3.75	3.75	3.75
Min. domestic inlet pressure for max. DHW flow rate (bar)	1.2	1.4	1.6	1.9
Min. domestic inlet pressure to operate the appliance (bar)	0.2	0.2	0.2	0.2
Max. domestic inlet pressure (bar)	10	10	10	10
DHW flow rate @ 35°CΔT (l/min)	11.1	12.6	15.2	17.2
DHW flow rate @ 40°CΔT (l/min)	9.7	11.1	13.3	15.1
Output to central heating	kW (Btu/h)	kW (Btu/h)	kW (Btu/h)	kW (Btu/h)
	7.7 - 26.2 (26,272 - 89,394)	7.7 - 30 (26,272 - 102,360)	9.4 - 30 (32,073 - 102,360)	9.4 - 30 (32,073 - 102,360)
Wall mounting jig	•	•	•	•
Filling link	•	•	•	•
Plug-in timers	• (optional)	• (optional)	• (optional)	• (optional)
Optimising room temperature controller	• (optional)	• (optional)	• (optional)	• (optional)
Intelligent controls	• (optional)	• (optional)	• (optional)	• (optional)
Condensing in DHW mode	•	•	•	•
Max. vertical flue (mm) (100mm dia.) inc. terminal	11,500	8,000	8,000	7,500
Max. vertical flue (mm) (125mm dia.) inc. terminal	23,000	16,000	16,000	16,000
Max. horizontal flue (mm) (100mm dia.)	10,000	7,000	6,500	6,000
Max. horizontal flue (mm) (125mm dia.)	23,000	16,000	16,000	12,000
NOx classification (mg/kWh)	33.3	33.3	21.8	21.8
NOx class	5	5	5	5

Installing the Greenstar combi range

All combi boilers require less installation time than a conventional boiler, for these reasons:

- All the major components, including the pump, are contained within the boiler casing and do not need to be fitted separately
- The boiler comes pre-wired and pre-plumbed
- There is no need to install a hot water cylinder
- There is no need to install a storage tank in the roof space
- There is less pipework in the heating system
- One-man lift (Greenstar i Junior and Greenstar Si)
- The boiler comes supplied with a wall mounting bracket (Greenstar CDi) or a wall mounting jig (Greenstar i Junior and Greenstar Si)
- Automatic gas pressure adjustment
- Highly versatile multi-directional fluing system
- Combined ignition and control board means less connections
- Plug-in filling link (optional on Greenstar i Junior and Greenstar Si)
- Optional plug-in timers
- Built-in frost protection
- Vertical pre-piping assembly accessory providing pre-formed copper pipe lengths and an earth-bonding strip (Greenstar i Junior and Greenstar Si only)

Siting of appliance

General

The appliances are only suitable for installing internally within a property at a suitable location onto a fixed, rigid surface at least the same size as the appliance and capable of supporting its weight.

No surface protection is required against heat transfer from the boiler. However, if the appliance is to be fitted in a timber frame building the guidelines laid down in BS 5440:Part 1 and the CORGI publication "Gas Installations in Timber Frame Buildings" should be adhered to.

The appliances may be installed into an airing cupboard if required. Use a non-combustible perforated material (max. hole sizes of 13mm) to separate the boiler from the airing space. See section "Compartment Installation" on page 19.

Clearances

The minimum clearances shown below should be allowed for installation and servicing. Compartment ventilation would be required at these clearances.

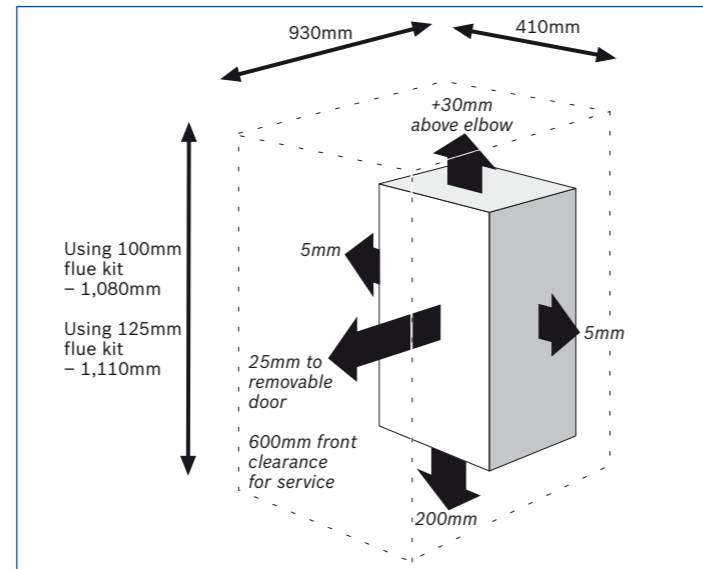

Clearances for Greenstar i Junior and Greenstar Si

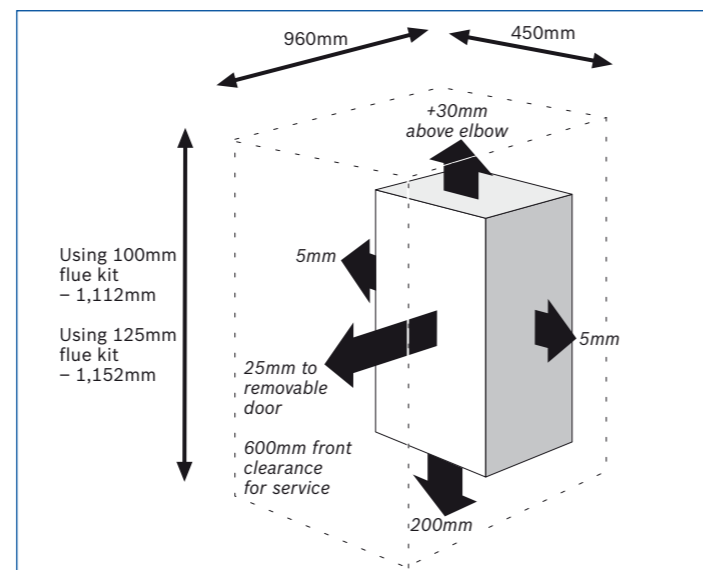

Clearances for Greenstar CDi

Compartment installation

The appliance may be installed in any room, although particular attention is drawn to the requirements of the IEE regulations applicable and in Scotland the electrical provisions with respect to installation in a room containing a bath or shower.

1. The room in which the appliance is installed does not require a purpose provided air vent.
2. If the appliance is installed in a cupboard or compartment with dimensions that allow the following minimum clearances, then no ventilation is required:

Position of appliance	Min. unventilated clearance (to removable door)	
	Greenstar i Junior & Si	Greenstar CDi
In front	100mm	20mm
Below	200mm	200mm
Right side	200mm*	5mm
Left side	200mm*	5mm
Above flue elbow	30mm	30mm

Ventilation free compartment installation - minimum clearances

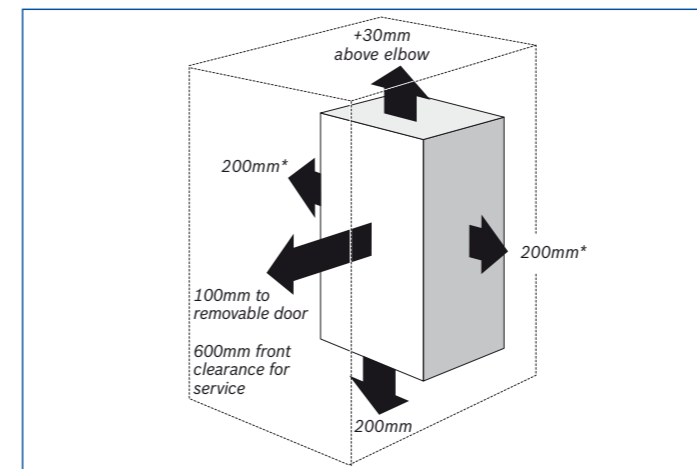

Greenstar i Junior and Greenstar Si

*This can be reduced to 50mm for one side, provided that the total side clearances add up to 400mm or more.

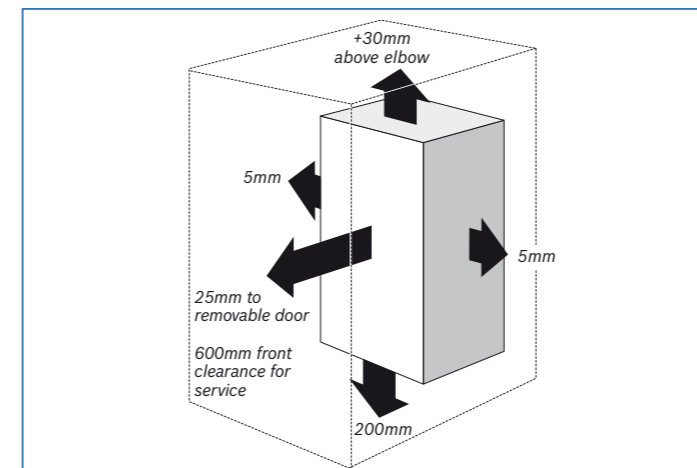

Greenstar CDi

Wall preparation

The following diagrams show the wall mounting jigs which enable a simple and straightforward method of attaching the boiler to the wall surface. The new design wall mounting jig for the Greenstar i Junior and Greenstar Si is made from light-weight polycarbonate ABS plastic with steel cross members.

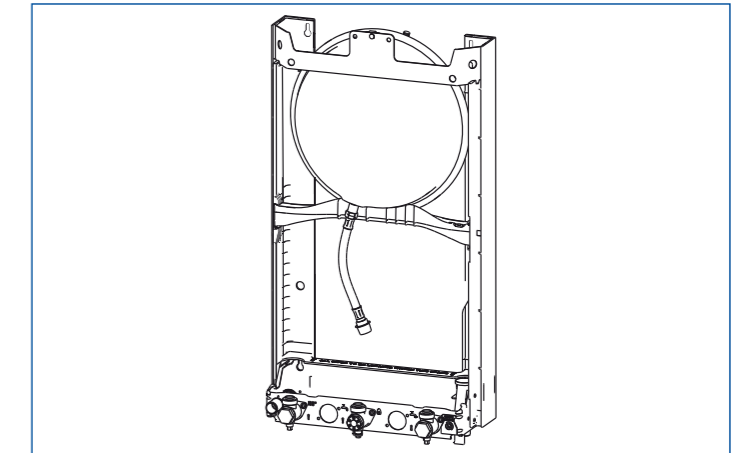

Greenstar i Junior and Greenstar Si wall mounting jig

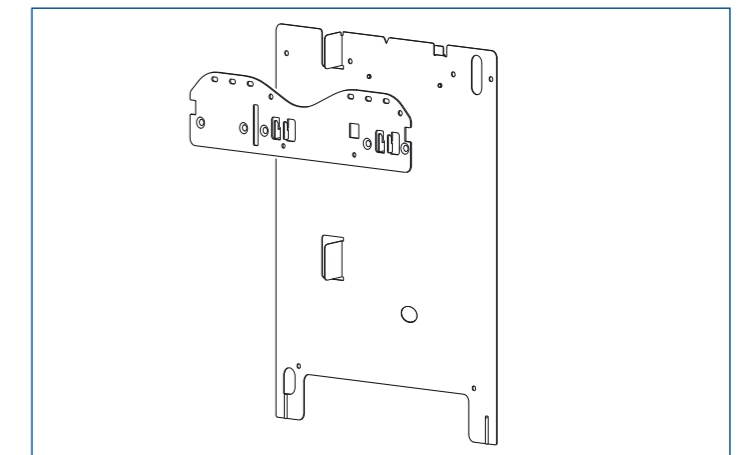

Greenstar CDi wall mounting jig

Additional fixing points have been pre-drilled and a small integral spirit level make hanging a Worcester Greenstar i Junior or Greenstar Si combi boiler easier than ever.

The Greenstar CDi wall mounting jig has additional optional fixing points and provides improved engagement.

After fixing the jig to the wall, the appliance can be lifted onto the jig and the union connections tightened. The pipework can be routed behind the boiler without the need for an additional wall spacing frame.

Optional accessories

The vertical pre-piping assembly kits comprises a set of pre-formed copper pipes and an electrical cross-bonding strip. For part numbers see pages 44 and 45.

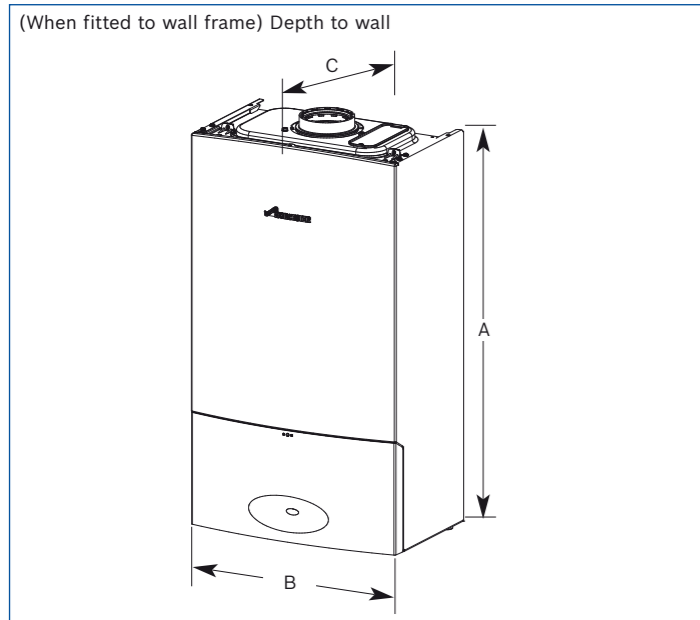

Greenstar i Junior and Greenstar Si

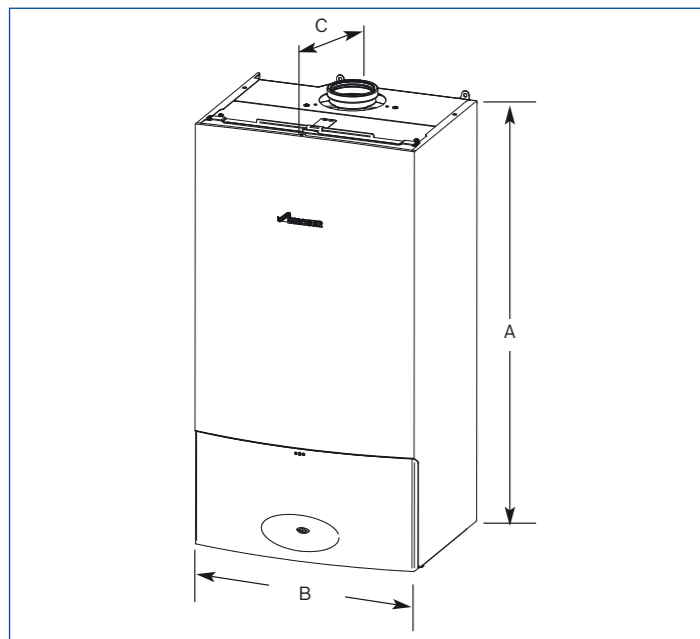

Greenstar CDi

Cabinet dimensions (mm)	
Greenstar i Junior and Si	
A	700*
B	400
C	330
Greenstar CDi	
A	750**
B	440
C	360

*710mm to top of casing front.

**760mm to top of casing front.

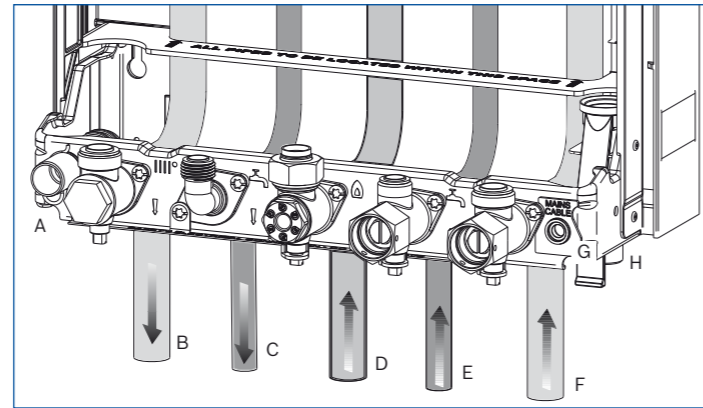

Greenstar i Junior and Greenstar Si

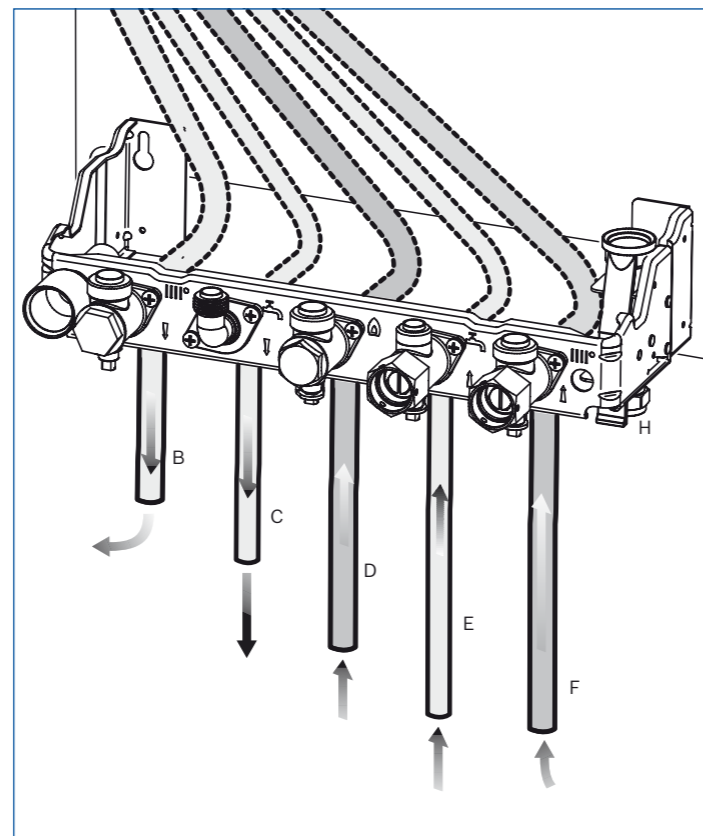

Greenstar CDi

Pipework connections		
A	Universal condensate fitting	
B	CH flow	22mm
C	DHW outlet	15mm
D	Gas inlet	22mm
E	Mains water inlet	15mm
F	CH return	22mm
G	Mains cable grommet	
H	Pressure relief valve	

Boiler location & clearances

Bathrooms

IMPORTANT:

Any switch or appliance control using mains electricity must not be within reach of a person using the bath or shower.

Electrical switches, fused spurs and socket outlets must not be situated in the bathroom.

A boiler fitted with a non-mechanical timer or with no timer can be installed in zone 2 or outside the shaded area.

A boiler with a mechanical timer or RF mechanical timer with a room thermostat must only be installed outside the shaded area.

Additional Residual Current Device (RCD) protection may be required.

Refer to the latest IEE wiring regulations.

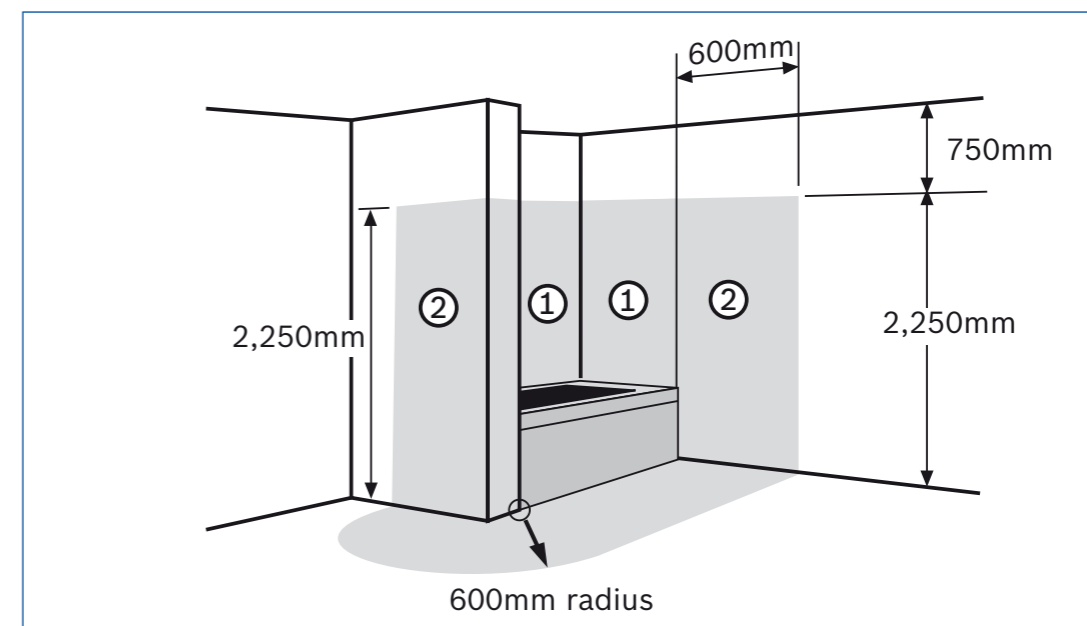
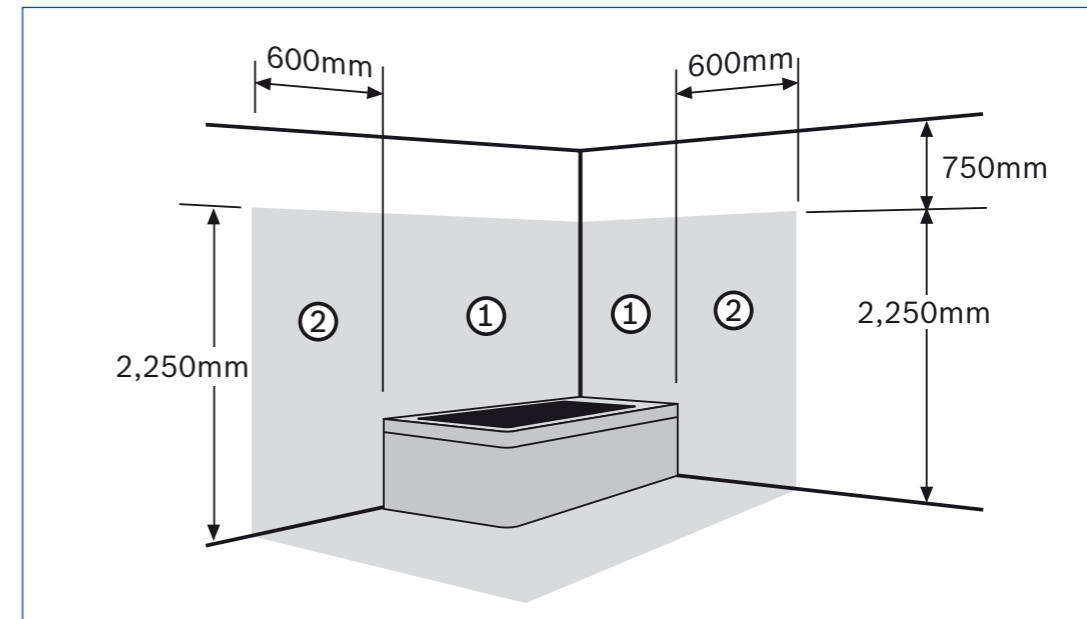

Condensate pipe work

- Where a new or replacement boiler is being installed, access to an internal “gravity discharge” point should be one of the factors considered in determining boiler location
- The condensate pipe must be a minimum of 22mm dia. plastic pipe
- The condensate pipe work must fall at least 50mm per metre towards the outlet and should take the shortest practicable route
- Ensure there are no blockages in the pipe run.

Internal connections

In order to minimise risk of freezing during prolonged cold spells, the following methods of installing condensate drainage pipe should be adopted, in order of priority.

Wherever possible, the condensate drainage pipe should be routed and terminated so that the condensate drains away from the boiler under gravity to a suitable internal foul water discharge point such as an internal soil and vent stack. A suitable permanent connection to the foul waste pipe should be used (see fig. 1).

Alternatively if the first option is not possible an internal kitchen or bathroom waste pipe, washing machine waste pipe etc. can be used (see fig. 2).

Condensate pump

Where “gravity discharge” to an internal termination is not physically possible, or where very long internal runs would be required to reach a suitable discharge point, condensate should be removed using a proprietary condensate pump, of a specification recommended by the boiler or condensate pump manufacturer.

The pump outlet pipe should discharge to a suitable internal foul water discharge point such as an internal soil and vent stack, internal kitchen or bathroom waste pipe, washing machine waste pipe etc. A suitable permanent connection to the foul waste pipe should be used (see fig. 3).

Internal condensate pipe work

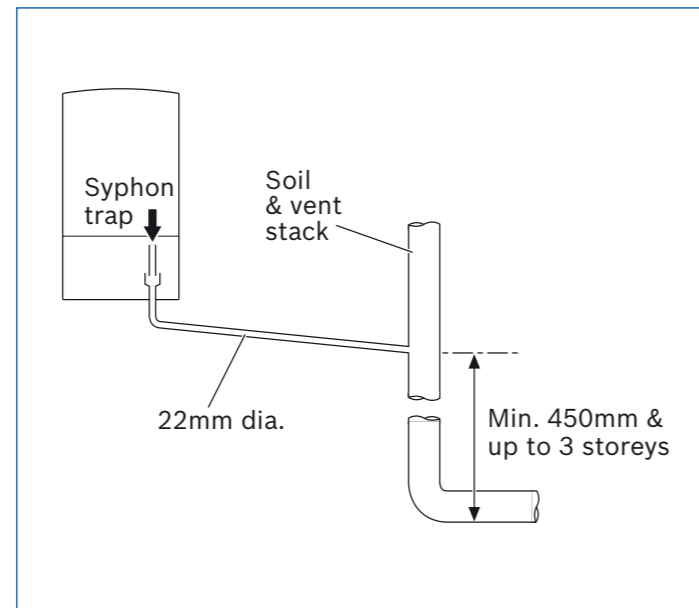

Fig. 1 Disposal to soil vent stack

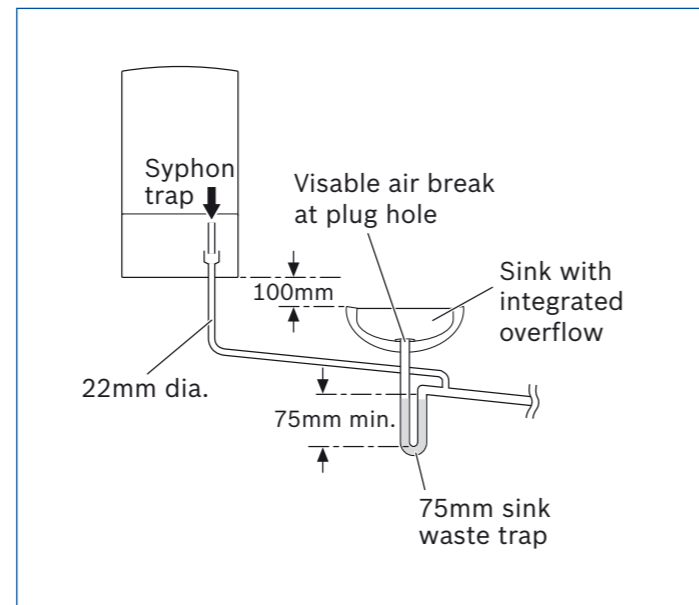

Fig. 2 Disposal to a waste pipe

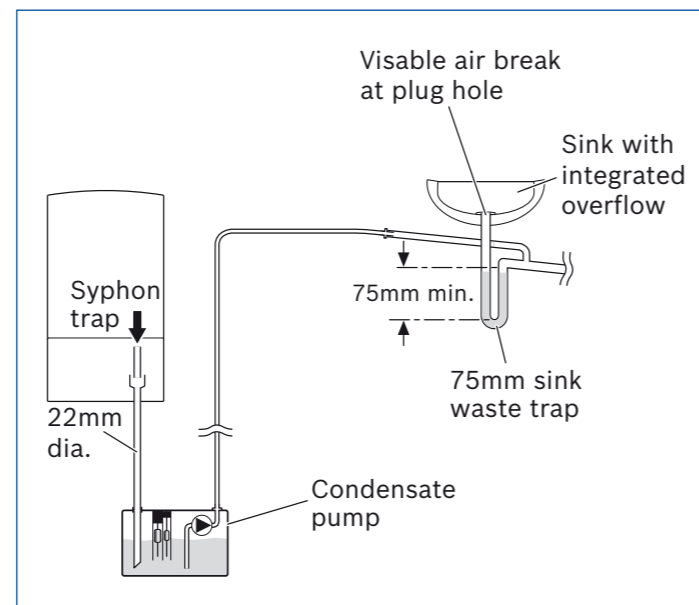

Fig. 3 Condensate pump disposal

External connections

Freezing conditions

- Pipe work length should be kept to a minimum and the route as vertical as possible
- Where pipe work is subjected to extreme cold or wind chill, a weather proof insulation should be used.

Condensate waste

- Care should be taken when siting a soak away to avoid obstructing existing services.

If no other discharge method is possible then the use of an externally run condensate drainage pipe terminating at a suitable foul water discharge point, or purpose-designed soak away, may be considered.

If this method is chosen then the following measures should be adopted:

- The external run be kept as short as possible and not exceed three metres.
- The pipe should be run internally as far as possible before going externally and the pipe diameter should be increased to 32mm before it passes through the wall to the exterior. The pipe should be insulated using suitable waterproof and weather resistant insulation.
- The external pipe should take the shortest and least exposed route to the discharge point, and should “fall” as steeply as possible away from the boiler, with no horizontal runs in which condensate might stand.
- The use of fittings, elbows etc. should be kept to a minimum and any internal “burrs” on cut pipe work should be removed so that the internal pipe section is as smooth as possible.

Fitting an external air break

- Refer to figure 4. When a rain water down pipe, that goes directly into a sewer that carries both rainwater and foul water, is used to dispose of condensate.
- An air break must be installed in the 43 mm pipe work, between the boiler condensate outlet and the drainpipe, outside the property, to avoid flooding during adverse weather conditions.

Condensate drainage pipe can be run above or below ground.

Where the pipe terminates over an open drain or gully, the pipe should terminate below the grating level, but above water level, in order to minimise “wind chill” at the open end.

The use of a drain cover (such as those used to prevent blockage by leaves) may offer further protection from wind chill.

Pipe drainage will be improved if the end is cut at 45° angle as opposed to a straight cut. (see fig. 5)

Condensate soak away

- The condensate drainage pipe may be run above or below the ground to the soak away.
- The examples shown on this page run above ground.
- The soak away must use a 100mm dia. plastic tube with two rows of three 12mm holes on 25mm centres and 50mm from the bottom of the tube. The holes must face away from the house.
- The tube must be surrounded by at least 100mm of limestone chippings to a depth of 400mm.

Minimum hole size for the condensate soak away must be 400mm deep by 300mm dia.

In situations where there are likely to be extremes of temperature or exposure, the use of a proprietary trace heating system for external pipe work, incorporating an external frost thermostat, should be considered. If such a system is used, the requirement to use 32mm pipe does not apply, however all other guidance above, and the instructions for the trace heating system, should be closely followed.

Unheated internal areas

- Internal pipe runs in unheated areas such as lofts, basements and garages should be treated as external runs.

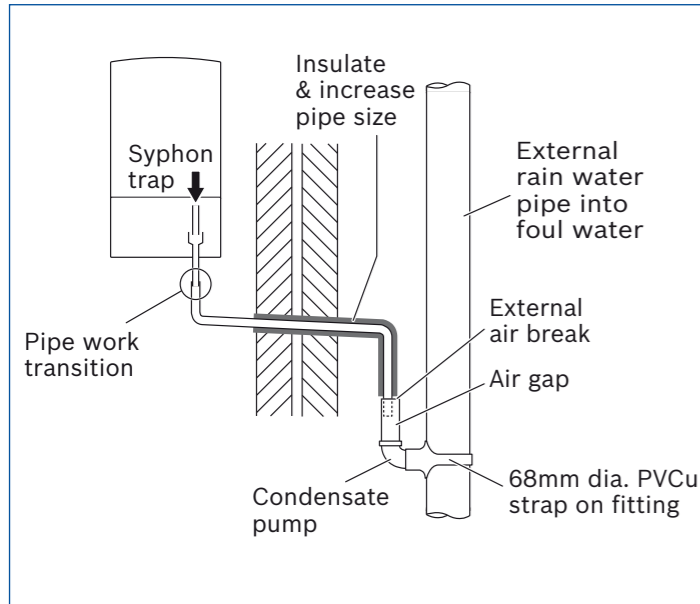

Fig. 4 Disposal into a rainwater down pipe

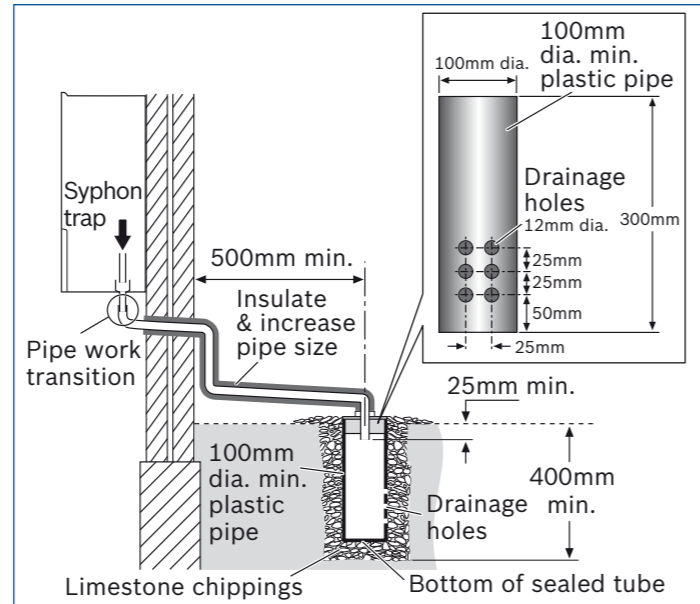

Fig. 6 Soak away

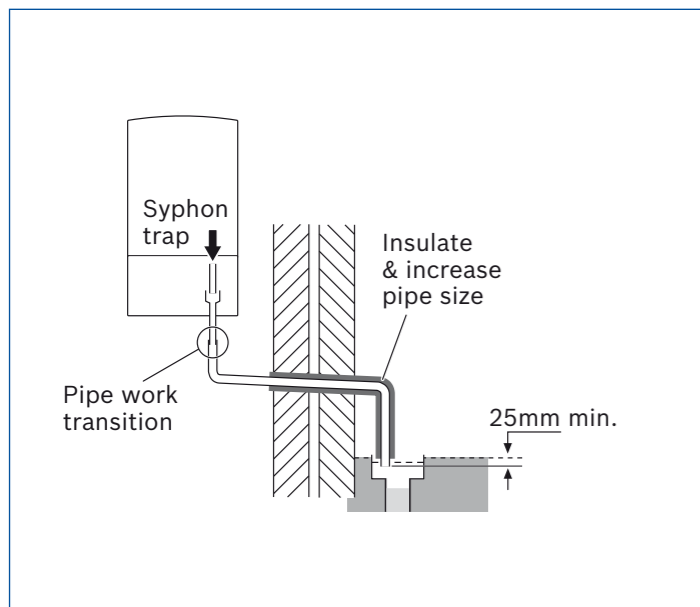

Fig. 5 External disposal

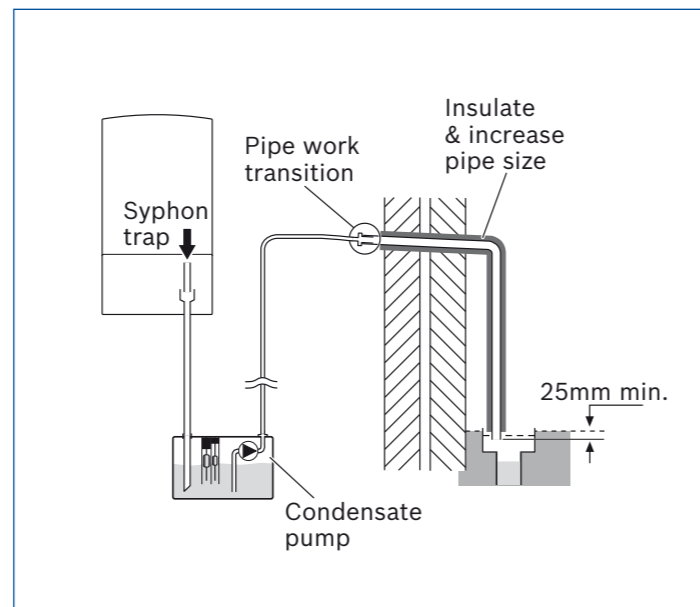
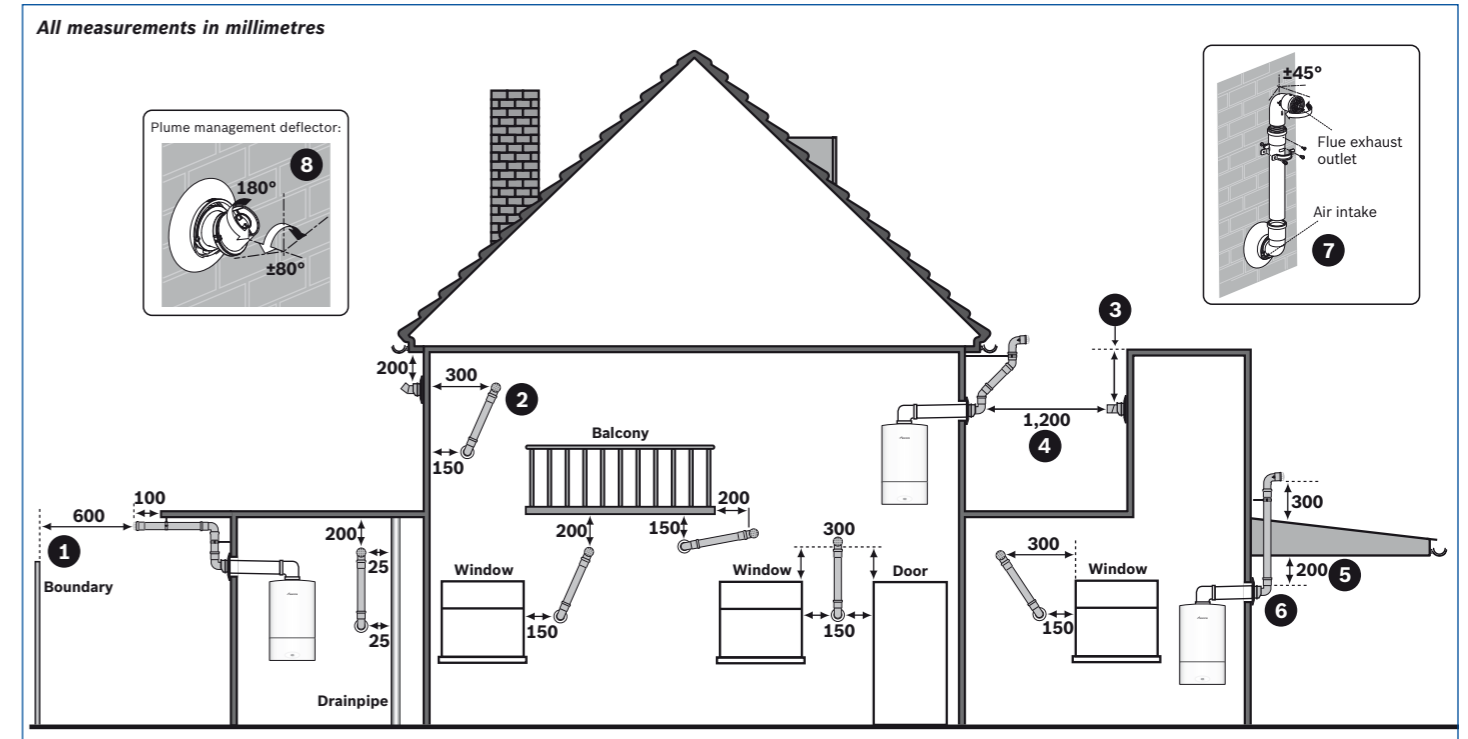

Fig. 7 Condensate pump to external disposal

Plume management terminal positioning



Note

- All measurements are the minimum clearances required.
- Terminals must be positioned so to avoid combustion products entering the building.
- Support the flue at approximately one metre intervals and at a change of direction, use suitable brackets and fittings.

Key to illustration

1. 600mm distance to a boundary or surface facing a boundary, unless it will cause a nuisance. BS 5440: Part 1 recommends that care is taken when siting terminals in relation to boundaries.
2. Internal/external corners. The air intake clearance can be reduced to 150mm providing the flue exhaust outlet has a 300mm clearance.
3. The flue cannot be lower than 1,000mm from the top of the light well due to the build up of combustion products.
4. 1,200mm between air intake and facing terminal.

5. Clearance no less than 200mm from the lowest point of the balcony or overhang.

Installations in car ports are not recommended.

6. 1,200mm from an opening in a car port on the same wall i.e. door or window leading into dwelling.
7. Using a Plume Management Kit the air intake measurement can be reduced to 150mm providing the flue exhaust outlet has a 300mm clearance. Plume kits running horizontally must have a 10° fall back to the boiler for proper disposal of condensate. For details on specific lengths see relevant boiler Technical & Specification information.
8. This feature allows some basic plume re-direction options on a standard telescopic horizontal flue terminal. 300mm minimum clearances to an opening e.g. window. However the minimum clearance to an opening in direction that the plume management is facing, must be increased to 1,500mm. Where the flue is less than 150mm to a drain pipe and plume re-direction is used the deflector should not be directed towards the drainpipe.

All measurements in millimetres

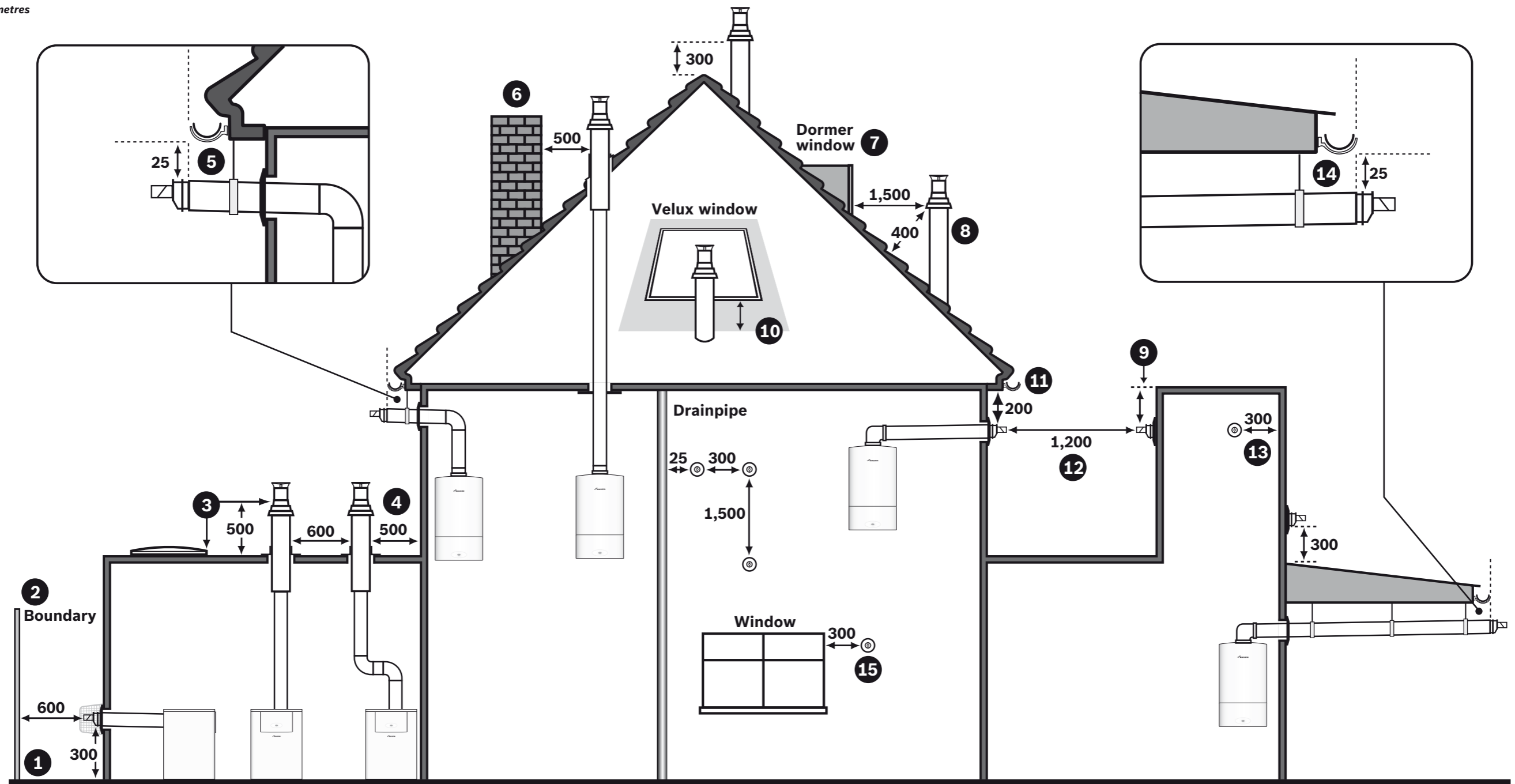

Note

- All measurements are the minimum clearances required.
- Terminals must be positioned so to avoid combustion products entering the building.
- Support the flue at approximately one metre intervals and at a change of direction, use suitable brackets and fittings (flue bracket part numbers: 100mm – 7 716 191 092, 125mm – 7 716 191 174).

Key to illustration

1. Flue clearance must be at least 300mm from the ground. Terminal guards must be fitted if the flue is less than 2 metres from the ground or if a person could come into contact with the flue terminal.
2. 600mm distance to a boundary, unless it will cause a nuisance. BS 5440: Part 1 recommends that care is taken when siting terminals in relation to boundaries.
3. 600mm minimum clearance from a skylight to a vertical flue.
4. Vertical flue clearance, 500mm to non-combustible building material, and 1,500mm clearance to combustible building material.

5. The dimension below eaves, gutters, pipes and drains can be reduced to 25mm, as long as the flue terminal is extended to clear any overhang. Any external flue joints must be sealed with a suitable silicon sealant.
6. 500mm clearance to any vertical structure on a roof, 600mm to room sealed flue or 1,500mm to an open flue.
7. 1,500mm between a vertical flue terminal and a window or dormer window.
8. 400mm from a pitched roof or in regions with heavy snow fall 500mm.
9. The flue cannot be lower than 1,000mm from the top of a light well due to the build up of combustion products.
10. 2,000mm below a Velux window, 600mm above or to either side of the Velux window.

11. 200mm below eaves and 75 mm below gutters, pipes and drains.

12. 1,200mm between terminals facing each other.

13. 300mm to an internal or external corner.

Installations in car ports are not recommended.

14. The dimension below eaves, balconies and car ports can be reduced to 25mm, as long as the flue terminal is extended to clear any overhang. Any external flue joints must be sealed with suitable silicon sealant.

15. 300mm above, below and either side of an opening door, air vent or opening window.

Greenstar combi boiler range horizontal fluing options

The Greenstar combi boiler range have the choice of 2 differently sized horizontal RSF flue systems, a 100mm diameter telescopic flue kit including a plume management kit and a 125mm diameter telescopic flue kit. Both systems have different maximum lengths. Options 1 to 6 detail the permissible lengths.

Horizontal RS flue

Flue diameter	100mm	125mm
Greenstar i Junior and Greenstar Si series		
Minimum flue length	350mm*	405mm
Maximum flue length	4,600mm	13,000mm
Greenstar CDi series		
Minimum flue length	350mm*	405mm
Maximum flue length	27CDi 10,000mm	23,000mm
	30CDi 7,000mm	16,000mm
	37CDi 6,500mm	16,000mm
	42CDi 6,000mm	12,000mm

*Can be cut to 130mm. Please refer to instructions.

100mm dia. standard telescopic flue kit

Comprises:

- 1 x flue turret elbow
- 570mm (100mm dia.) of flue duct
- 1 x weather sealing ring
- 1 x internal collar

Part No. 7 716 191 082

125mm dia. standard telescopic flue kit

- 1 x flue turret elbow
- 600mm (125mm dia.) of flue duct including terminal (as measured from centre of flue outlet)
- 1 x weather sealing plate
- 1 x internal plate

Part No. 7 719 003 702

Accessories



Components	Part no.	Description
	7 716 191 082	100mm dia. standard telescopic flue kit (350 - 570mm)
	7 716 191 171	100mm dia. long telescopic flue kit (570 - 790mm)
	7 716 191 083	100mm dia. extension flue kit (960mm*)
	7 716 191 172	100mm dia. 2m flue extension
	7 716 191 133	100mm dia. short flue extension (220mm*)
	7 716 191 084	100mm dia. 90° bend
	7 716 191 085	100mm dia. 45° bend
	7 719 002 432	100mm dia. high level horizontal adaptor
	7 716 191 092	100mm dia. support bracket kit
	7 716 191 173	100mm dia. support bracket kit (6 pack)
	7 719 003 702	125mm dia. standard telescopic flue kit
	7 719 003 666	125mm dia. extension flue kit (960mm*)
	7 719 003 664	125mm dia. 90° bend
	7 719 003 665	125mm dia. 45° bend
	7 719 002 433	125mm dia. high level horizontal adaptor
	7 716 191 174	125mm dia. support bracket kit

*Dimensions when fitted

The following criteria should be noted when planning the installation.

- The concentric flue system must be inclined at 3° (50mm per metre) from the appliance, to allow condensate to drain back into the boiler.
- Because the appliance operates at high efficiency a white plume of condensation will be emitted from the terminal. Care must be taken when selecting the flue terminal position.

Option 1 Standard horizontal flue assembly

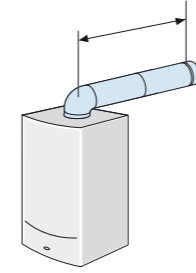

Maximum length (mm)	Components required	
Greenstar i Junior and Greenstar Si series		
100mm 570	1	
125mm 600	1	
Greenstar CDi series		
100mm 570	1	
125mm 600	1	

Option 2 Extension flue horizontal

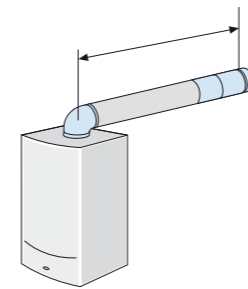

Maximum length (mm)	Components required	
Greenstar i Junior and Greenstar Si series		
100mm 4,600	1	up to 5
125mm 13,000	1	up to 13
Greenstar 27CDi		
100mm 10,000	1	up to 10
125mm 23,000	1	up to 23
Greenstar 30CDi		
100mm 7,000	1	up to 7
125mm 16,000	1	up to 16
Greenstar 37CDi		
100mm 6,500	1	up to 6
125mm 16,000	1	up to 16
Greenstar 42CDi		
100mm 6,000	1	up to 6
125mm 12,000	1	up to 12

Option 3 Extension flue horizontal using a second 90° bend

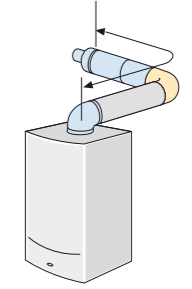

Maximum length (mm)	Components required		
Greenstar i Junior and Greenstar Si series			
100mm 2,600	1	up to 3	1
125mm 11,000	1	up to 11	1
Greenstar 27CDi			
100mm 8,500	1	up to 8	1
125mm 21,000	1	up to 21	1
Greenstar 30CDi			
100mm 5,500	1	up to 5	1
125mm 14,000	1	up to 14	1
Greenstar 37CDi			
100mm 5,000	1	up to 5	1
125mm 14,000	1	up to 14	1
Greenstar 42CDi			
100mm 4,500	1	up to 4	1
125mm 10,000	1	up to 10	1

Note: The short flue extension (100mm dia.) may be used as an alternative to the standard extension as required up to the maximum flue lengths stated (7 716 191 133).

Note: The maximum flue length must be reduced by the following amounts for each bend used.

	Greenstar i Junior & Si – all size flues	Greenstar CDi 60/100mm flues	Greenstar CDi 80/125mm flues
45° bend	1m	0.75m	1m
90° bend	2m	1.5m	2m

Option 4

Extension flue horizontal and upwards

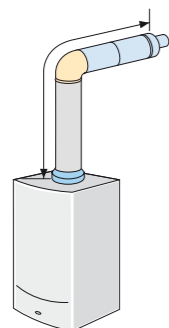

Maximum length (mm)		Components required			
Greenstar i Junior and Greenstar Si series					
100mm	4,600	1	up to 5	1	1
125mm	13,000	1	up to 13	1	1
Greenstar 27CDi					
100mm	10,000	1	up to 10	1	1
125mm	23,000	1	up to 23	1	1
Greenstar 30CDi					
100mm	7,000	1	up to 7	1	1
125mm	16,000	1	up to 16	1	1
Greenstar 37CDi					
100mm	6,500	1	up to 6	1	1
125mm	16,000	1	up to 16	1	1
Greenstar 42CDi					
100mm	6,000	1	up to 6	1	1
125mm	12,000	1	up to 12	1	1

Note: The short flue extension (100mm dia.) may be used as an alternative to the standard extension as required up to the maximum flue lengths stated (7 716 191 133).

Note: The maximum flue length must be reduced by the following amounts for each bend used.

	Greenstar i Junior & Si – all size flues	Greenstar CDi 60/100mm flues	Greenstar CDi 80/125mm flues
45° bend	1m	0.75m	1m
90° bend	2m	1.5m	2m

Option 5

Extension flue upwards and horizontal using a second 90° bend

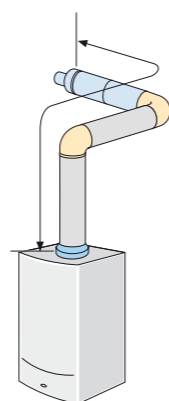

Maximum length (mm)		Components required			
Greenstar i Junior and Greenstar Si series					
100mm	2,600	1	up to 3	2	1
125mm	11,000	1	up to 11	2	1
Greenstar 27CDi					
100mm	8,500	1	up to 8	2	1
125mm	21,000	1	up to 21	2	1
Greenstar 30CDi					
100mm	5,500	1	up to 5	2	1
125mm	14,000	1	up to 14	2	1
Greenstar 37CDi					
100mm	5,000	1	up to 5	2	1
125mm	14,000	1	up to 14	2	1
Greenstar 42CDi					
100mm	4,500	1	up to 4	2	1
125mm	10,000	1	up to 10	2	1

Option 6

Extension flue upwards and horizontal using a third 90° bend

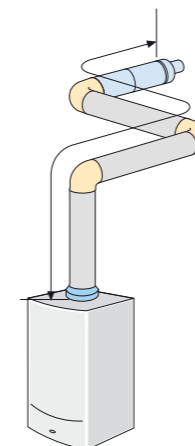

Maximum length (mm)		Components required			
Greenstar i Junior and Greenstar Si series					
125mm	9,000	1	up to 9	3	1
Greenstar 27CDi					
100mm	7,000	1	up to 7	3	1
125mm	19,000	1	up to 19	3	1
Greenstar 30CDi					
100mm	4,000	1	up to 4	3	1
125mm	12,000	1	up to 12	3	1
Greenstar 37CDi					
100mm	3,500	1	up to 3	3	1
125mm	12,000	1	up to 12	3	1
Greenstar 42CDi					
100mm	3,000	1	up to 3	3	1
125mm	8,000	1	up to 8	3	1

45° options available

Note: The short flue extension (100mm dia.) may be used as an alternative to the standard extension as required up to the maximum flue lengths stated (7 716 191 133).

Note: The maximum flue length must be reduced by the following amounts for each bend used.

	Greenstar i Junior & Si – all size flues	Greenstar CDi 60/100mm flues	Greenstar CDi 80/125mm flues
45° bend	1m	0.75m	1m
90° bend	2m	1.5m	2m

Greenstar combi boiler range vertical fluing options

The Greenstar combi boiler range have the choice of 2 differently sized vertical RSF flue systems, 100mm and 125mm. Both systems have different maximum lengths. Options 1 to 4 detail the permissible lengths.

Vertical RSF flue

Flue diameter	100mm	125mm
Greenstar i Junior and Greenstar Si series		
Minimum flue length	1,090mm	1,365mm
Maximum flue length (inc. adaptor)	6,400mm	15,000mm
Greenstar CDi series		
Minimum flue length	1,140mm	1,365mm
Maximum flue length (inc. adaptor)		
27CDi	11,500mm	23,000mm
30CDi	8,000mm	16,000mm
37CDi	8,000mm	16,000mm
42CDi	7,500mm	16,000mm

Vertical balanced flue kit

Comprises:

- 1 x flue terminal assembly
- 1 x weather sealing collar
- 1 x fire stop spacer
- 1 x vertical adaptor

Part No. 7 719 002 430 (100mm dia.)

Part No. 7 719 002 431 (125mm dia.)

Accessories



Components	Part no.	Description
	7 719 002 430	100mm dia. vertical balanced flue kit
	7 716 191 083	100mm dia. extension flue kit (960mm*)
	7 716 191 133	100mm dia. short flue extension (220mm*)
	7 716 191 084	100mm dia. 90° bend
	7 716 191 085	100mm dia. 45° bend
	7 719 002 431	125mm dia. vertical balanced flue kit
	7 719 003 666	125mm dia. extension flue kit (960mm*)
	7 719 003 664	125mm dia. 90° bend
	7 719 003 665	125mm dia. 45° bend
	7 716 191 090	Flashing – flat roof
	7 716 191 091	Flashing – pitched roof

*Dimensions when fitted

Option 1

Minimum height

Minimum length (mm)	Components required	
Greenstar i Junior and Greenstar Si series		
100mm	1,090	1
125mm	1,365	1
Greenstar 27CDi		
100mm	1,090	1
125mm	1,365	1
Greenstar 30CDi		
100mm	1,090	1
125mm	1,365	1
Greenstar 37CDi		
100mm	1,090	1
125mm	1,365	1
Greenstar 42CDi		
100mm	1,090	1
125mm	1,365	1

Note: The short flue extension (100mm dia.) may be used as an alternative to the standard extension as required up to the maximum flue lengths stated (7 716 191 133).

Option 2

Vertical balanced flue system maximum height

Maximum length (mm)	Components required		
Greenstar i Junior and Greenstar Si series			
100mm	6,400	1	up to 6
125mm	15,000	1	up to 14
Greenstar 27CDi			
100mm	11,500	1	up to 11
125mm	23,000	1	up to 22
Greenstar 30CDi			
100mm	8,000	1	up to 7
125mm	16,000	1	up to 15
Greenstar 37CDi			
100mm	8,000	1	up to 7
125mm	16,000	1	up to 15
Greenstar 42CDi			
100mm	7,500	1	up to 7
125mm	16,000	1	up to 15

Note: The maximum flue length must be reduced by the following amounts for each bend used.

	Greenstar i Junior & Si – all size flues	Greenstar CDi 60/100mm flues	Greenstar CDi 80/125mm flues
45° bend	1m	0.75m	1m
90° bend	2m	1.5m	2m

Option 3

Vertical balanced flue system with two 45° bends

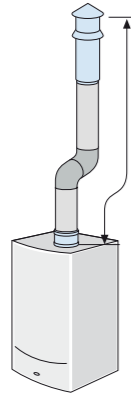

Maximum length (mm)	Components required		
Greenstar i Junior and Greenstar Si series			
100mm 4,400	1	up to 4	2
125mm 13,000	1	up to 12	2
Greenstar 27CDi			
100mm 10,000	1	up to 9	2
125mm 21,000	1	up to 20	2
Greenstar 30CDi			
100mm 6,500	1	up to 6	2
125mm 14,000	1	up to 13	2
Greenstar 37CDi			
100mm 6,500	1	up to 6	2
125mm 14,000	1	up to 13	2
Greenstar 42CDi			
100mm 6,000	1	up to 5	2
125mm 14,000	1	up to 13	2

Option 4

Vertical balanced flue system with two 90° bends

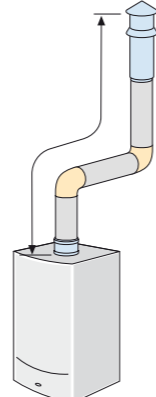

Maximum length (mm)	Components required		
Greenstar i Junior and Greenstar Si series			
100mm 2,400	1	up to 2	2
125mm 11,000	1	up to 10	2
Greenstar 27CDi			
100mm 8,500	1	up to 8	2
125mm 19,000	1	up to 18	2
Greenstar 30CDi			
100mm 5,000	1	up to 4	2
125mm 12,000	1	up to 11	2
Greenstar 37CDi			
100mm 5,000	1	up to 4	2
125mm 12,000	1	up to 11	2
Greenstar 42CDi			
100mm 4,500	1	up to 4	2
125mm 12,000	1	up to 11	2

Greenstar combi boiler range plume management system options

Plume management system

60mm dia. plume management kit

Comprises:

- 1 x terminal bend
- 1 x extension 500mm
- 1 x outlet assembly
- 1 x clamp pack

Part No. 7 716 191 086

Accessories

Components	Part no.	Description
	7 716 191 086	60mm dia. plume management kit
	7 716 191 087	60mm dia. extension (1,000mm)
	7 716 191 088	60mm dia. 90° bend
	7 716 191 089	60mm dia. 45° bend (pair)
	7 716 191 176	60mm dia. plume management terminal guard round

Standard plume management system

The flue terminal outlet has built-in stops to limit rotation for horizontal fluing to allow condensate to run back into the boiler for safe disposal. Do not attempt to force beyond the limit stops.

All plume management sections must rise by at least 173mm per metre (10°) from the terminal to ensure that condensate flows back into the boiler.

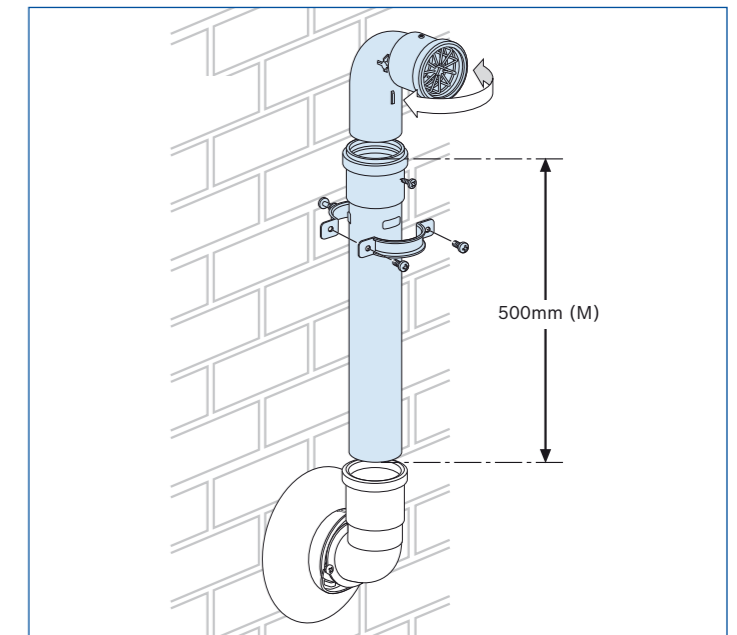

Note: The short flue extension (100mm dia.) may be used as an alternative to the standard extension as required up to the maximum flue lengths stated (7 716 191 133).

Note: The maximum flue length must be reduced by the following amounts for each bend used.

	Greenstar i Junior & Si – all size flues	Greenstar CDi 60/100mm flues	Greenstar CDi 80/125mm flues
45° bend	1m	0.75m	1m
90° bend	2m	1.5m	2m

Re-directing flue discharge from a 60mm dia. plume management outlet

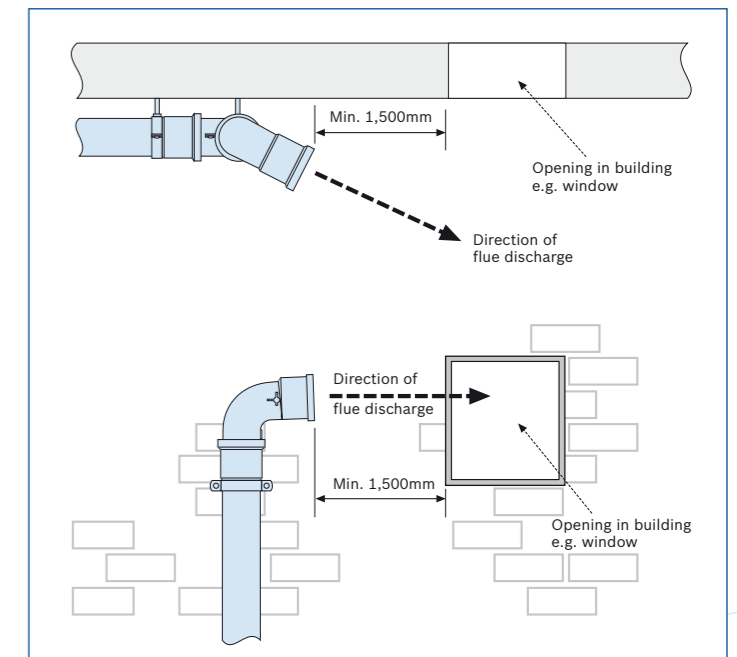

Condensfit II telescopic flue and plume management system measuring

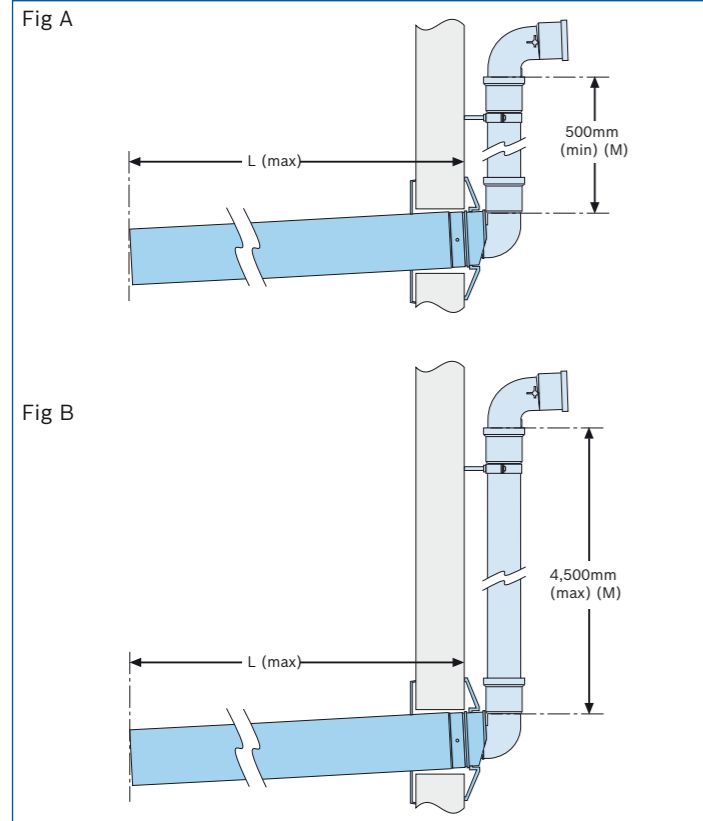

Effective straight flue lengths for telescopic flue with plume management		
Model	Fig. A Max. straight flue length (L) with min. plume management length 500mm (M)	Fig. B Max. straight flue length (L) with max. plume management length 4,500mm (M)
i Junior & Si series	4,600mm	4,600mm
27CDi	8,000mm	5,200mm
30CDi	5,000mm	2,200mm
37CDi	4,500mm	1,700mm
42CDi	4,000mm	1,200mm

Flue length 'L' versus plume management kit – Greenstar CDi

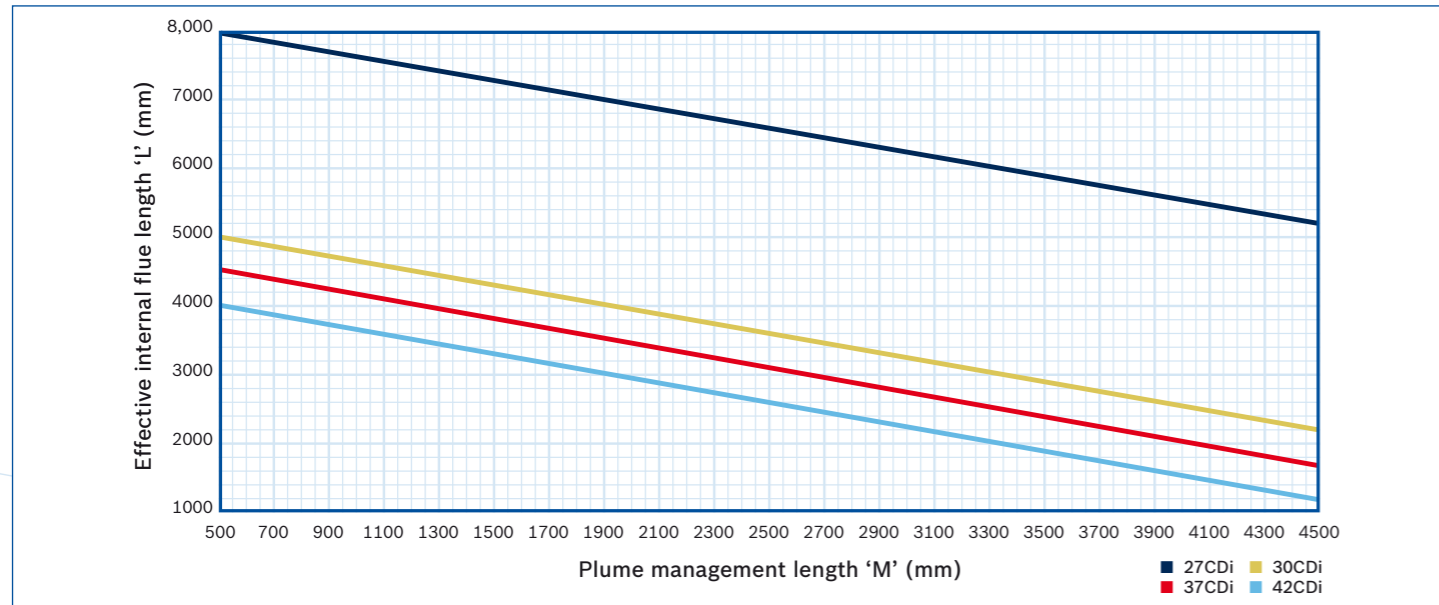

Greenstar i Junior and Greenstar Si boilers are able to use the maximum 100mm dia. internal flue length of 4,600mm regardless of the amount of plume management selected.

External plume management bends still need to be allowed for. See below.

For Greenstar CDi boilers the 100mm dia. internal flue length must be reduced by 700mm for every additional 1,000mm of plume management, refer to table and graph below.

60mm dia. plume management system

To ensure that the maximum total straight flue length along the plume management route is not exceeded the following should be added to dimension (M):

- 1,500mm for each extra 90° bend
- 750mm for each extra 45° bend

For plume management options with 60mm dia. extensions refer to page 37.

Use the graph below to determine the permissible plume management length that can be used with your effective flue length 'L'.

The effective flue length can be determined by adding together all the straight flue lengths and the effective lengths of the bends used, 2,000mm for each 90° bend and 1,000mm for each 45° bend.

Option 1
Plume management system

Minimum length (mm)	Components required	
Greenstar i Junior, Si and CDi* series		
60mm	500	1

Option 2
Plume management system with extensions

Maximum length (mm)	Components required	
Greenstar i Junior, Si and CDi* series		
60mm	4,500	up to 4

Option 3
Plume management system with extensions and 45° bend

Maximum length (mm)	Components required		
Greenstar i Junior, Si and CDi* series			
60mm	3,750	up to 4	1

Option 4
Plume management system with angled termination

Maximum length (mm)	Components required	
Greenstar i Junior, Si and CDi* series		
60mm	4,500	up to 4

Option 5
Plume management system with extensions and 45° bends

Maximum length (mm)	Components required		
Greenstar i Junior, Si and CDi* series			
60mm	3,000	up to 3	2

***NOTE: For CDi you must refer to the table and graph on page 36 to calculate your horizontal flue lengths and plume management length.**

Installation requirements

Installation of the Greenstar combi boiler range must be in accordance with the relevant requirements of the Gas Safety (Installation Use) Regulations (as amended), current IEE Wiring Regulations, local Building Regulations, Building Standards (Scotland) regulations and bylaws of the local Water company and Health and Safety Document No. 635 (Electricity at Work Regulations 1989). It should be in accordance with the relevant recommendations of the following British Standards:

BS 6798; BS 5449; BS 5546:1; BS 5440:1; BS 5440:2; BS 6891.

Gas Safety (Installation and Use) Regulations. All gas appliances must be installed by a Gas Safe registered person in accordance with the above regulations. Failure to install appliances correctly could lead to prosecution.

The manufacturer's notes must not be taken in any way as overriding statutory regulations.

Sealed primary systems

The Worcester Greenstar combi boilers are supplied complete with all the necessary components to form a sealed primary system. Included are an expansion vessel, a pressure relief valve (set at 3bar), an automatic air vent and a pressure gauge.

With an initial system pressure of 0.5bar a system capacity of approximately 83 litres can be accommodated. Refer to BS 7074:Part 1 for more information.

It is important with an aluminium heat exchanger that the pH level of the water does not exceed 8. Levels in excess of this could be detrimental to the heat exchanger.

The use of a suitable inhibitor will provide a resistance to this. Contact Sentinel (Tel: 0800 3894670) or Fernox (Tel: 01799 521133) for further details.

System filling and make-up

To comply with the Water Authority requirements, the system should be filled via a temporary hose connection to the mains cold water supply, with a double check valve assembly and test point fitted to the mains water side of a temporary circuit.

Greenstar i Junior and Si:

Alternatively, the plug-in filling link option (part number 7 716 192 281), simply connects between the cold main connection and the heating return circuit on the wall mounting jig. This part is supplied as standard with the Greenstar CDi.



Valves and joints

It is very important that all valves and joints are able to sustain a working pressure of up to 3bar (45psi). Particular care should be exercised when fitting radiator valves and only those of high quality to BS 2767:10 should be used. All other valves and fittings should comply with BS 1010.

Loss of water pressure from a sealed system will require continuous recharging with fresh water and consequential introduction of air. Air is highly corrosive and will considerably reduce life expectancy of radiators, pumps etc.

Plastic pipework

The use of plastic pipework is acceptable. However, some plastics are permeable to oxygen and must be avoided. Only pipework with a polymeric barrier should be used. Please note that the first 600mm of pipework connected to the boiler must be of copper or steel.

Natural gas supply

For the Greenstar i Junior when on a hot water or full output demand will require up to 3.02m³/hr of gas (depending on the model).

For the Greenstar Si when on a hot water or full output demand will require up to 3.24m³/hr of gas (depending on the model).

For the Greenstar CDi 42kW appliance when on a hot water or full output demand will require up to 4.4m³/hr of gas (figures for other appliances can be found in the relevant installation manuals).

The gas meter and supply pipes must be capable of supplying this quantity of gas in addition to the demand from any other appliance being served. It is important that a gas supply pipe of at least 22mm diameter is used. Under no circumstances should the size of the gas supply pipe be less than that of the appliance inlet connection. The meter outlet governor should be capable of ensuring a dynamic pressure of 20mbar (8in wg) at the appliance. Particular consideration should be given to the resistance to gas flow created by elbows, bends etc. Pipework should be sized to overcome this resistance, details of this are given in the table below.

	Total length of gas supply pipe (m)			Pipe diameter (mm)
	3	6	9	-
Gas discharge rate m ³ /h	2.9	-	-	15
	8.7	5.8	4.6	22
	18.0	12.0	9.4	28

Approximate additional length to be allowed (natural gas)

Elbows or tees		90° bends	
Metres	Feet	Metres	Feet
0.5	2	0.3	1

Liquid Petroleum Gas (LPG) supply

All Greenstar combi ranges are available in natural gas and LPG variants. The appliance when on a hot water or full output demand will require up to 2.22 kg/h of gas (depending on the model). The Greenstar Si models will require up to 2.38 kg/h of gas (depending on the model) at maximum demand.

The Greenstar CDi 42kW appliance when on a hot water or full output demand will require up to 3.3 kg/h of gas (figures for other appliances can be found in the relevant installation manual).

The gas tank or bottles must be capable of supplying this quantity of gas at a nominal pressure of 37mbar (14.8in wg) at the appliance. The table below shows the LPG gas discharge through varying lengths of pipe and the resistance to flow created by elbows, bends etc. Pipework should be sized to overcome this resistance.

	Total length of gas supply pipe (m)			Pipe diameter (mm)
	3	6	9	-
Gas discharge rate m ³ /h	1.5	1.01	-	15
	8.0	5.2	4.2	22
	15.9	8.9	8.3	28

Approximate additional length to be allowed (LPG)

Elbows or tees		90° bends	
Metres	Feet	Metres	Feet
0.6	2	0.3	1

Electricity supply

A 3amp fused three pin plug and unswitched shuttered socket outlet (both complying with BS 1362) or preferably a double pole isolator with a contact separation of 3mm in all poles supplying the appliance should be used.

The appliance electrical circuits are also protected by an internal 2amp fuse. The appliance must be earthed.

Mains cold water supply

Water Authority requirement

A direct mains cold water connection is permitted by Water Authorities. However, it is recommended that reference be made to local requirements. In the event of difficulty contact Worcester Technical Support Department.

Pipe sizing

Unless the mains pressure is low, a standard 15mm diameter service pipe is normally suitable. A 15mm hot water distribution pipe to the first branch is recommended thereafter 15mm and/or 10mm to all draw off points.

Cold water connection

Connection should be made as shown in the pipework detail and the appliance installed generally in accordance with the layout shown on page 20.

Wherever possible the cold supply to the appliance should be the first connection off the mains supply, in order to minimise hot water flow reduction when cold water services are operated. The final 600mm of piping to the appliance should be of copper only.

Cold water pressure

To achieve the stipulated flow rate a working cold water mains pressure of 1.3bar is required.

However, for the Greenstar CDi range to achieve the stipulated flow rate a working cold water mains pressure of between 1.2 and 2.3bar is required (dependent on model).

The appliance will operate at a minimum working pressure of only 0.2bar (3psi); however a reduced hot water flow rate should be expected. Back-flow prevention devices, including water meters, can prevent the expansion of hot water into the cold water main. However, this can result in a pressure build-up that may cause damage to the boiler and household devices such as showers, washing machines etc. In these cases we recommend that a mini-expansion vessel (Part No. 7 716 192 105) be fitted adjacent to the boiler in the cold water main.

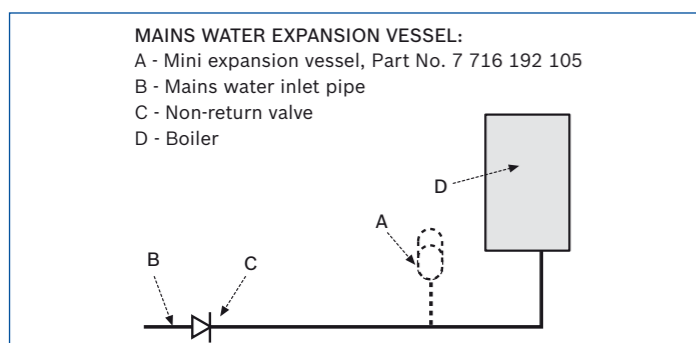

Hot water supply

A domestic hot water flow regulator, set to give an optimum flow rate of between 8 and 11l/min $\pm 15\%$ (dependent on model) is fitted to the cold supply of the hot water heat exchanger in the Greenstar i Junior and Si combis.

For the Greenstar CDi range, a domestic hot water flow regulator, set to give an optimum flow rate of between 9 and 15l/min $\pm 15\%$ (dependent on model) is fitted to the cold supply of the hot water heat exchanger.

As with all mains fed systems, the flow rate of water obtainable from individual taps will vary in relation to the number of taps operating simultaneously, and will depend upon the cold mains supply available to the property.

Therefore, in order to avoid excessive starvation of flow to individual taps, flow balancing may be required by the use of proprietary constant volume flow regulators or Ball-o-Fix valves.

Hot water systems

Taps and valves

Hot and cold taps and mixing valves used with the Greenstar combi range appliance must be suitable for operating at a mains pressure and temperatures of 65°C (150°F).

Showers

When a loose head shower with a flexible hose is used over a bath or shower tray, the hose must be fixed so that the head cannot fall closer than 25mm (1in) above the top edge of the spill over level of the relevant bath or shower tray. Alternatively, the feed pipes to the shower should incorporate a double check valve assembly or a check valve and vacuum breaker.

With fixed head showers no provision is necessary.

The use of a thermostatically controlled shower will give added comfort and safeguard against high hot water temperatures. Alternatively, a pressure balancing shower valve specifically designed for constant temperature water heaters would be suitable.

Bidet

The supply of hot and cold water mains direct to a bidet is permitted provided that the bidet is of the overrim water feed type. The outlet(s) should be shrouded and not to have any temporary hand held spray attached. No other anti-syphonage arrangements are necessary.

Use in hard water areas

As the maximum temperature of the domestic hot water heat exchanger is limited by the electronic control circuit, there is normally no need for water treatment to prevent scale accumulation.

In areas where exceptional water conditions prevail, consideration may need to be given to the fitting of a device capable of preventing scale. In such circumstances the advice of the local water authority should be sought.

Warranty

Worcester Greenstar combi range appliances are offered with a full 2 year guarantee* on parts and labour, a 10 year warranty* on the primary heat exchanger and a 5 year warranty* on the plate heat exchanger. Ongoing service and maintenance contracts can be arranged through the Worcester Customer Service Department.

Time and money saving accessories from Worcester

Vertical Pre-piping Assembly Kits

We are already the only manufacturer whose designs enable pipework to be run behind the boiler as standard and we're taking this feature a step further with our Pre-piping Assembly Kits. The pre-bent pipes have swaged-ends for easy soldering and will save you approximately 30 minutes on installation time.

The kits contain:

- 22mm CH flow pipe
- 22mm CH return pipe
- 15mm Mains water inlet pipe
- 15mm DHW outlet pipe
- 22mm Gas inlet pipe
- Earth bonding strip

The Pre-piping Assembly Kit can be used with Greenstar i Junior, Si and CDi combi boilers.

Earth Bonding Strip

Available as part of the kits and also separately, this not only looks neater, but saves up to 20 minutes on installation compared with fitting separate earth bonding tags to each pipe. It can be used with all Greenstar wall mounted gas-fired boilers.

Below Boiler Pipe Cover

Suitable for use with all Greenstar wall-hung appliances, this is a neat and simple solution for hiding the pipes on installations where they run below the boiler. The cover is curved to match the profile of the boiler fascia and is manufactured from white satin finished plastic.

To find out more, call 0844 892 3366 or visit our website.



Greenstar combi boiler range accessories

MT10 mechanical timer  Worcester Part No. 7 716 192 036	MT10RF mechanical RF thermostat  Worcester Part No. 7 716 192 037	DT20 twin channel digital programmer  Worcester Part No. 7 716 192 038	DT20RF digital RF thermostat with twin channel programmer  Worcester Part No. 7 716 192 054
DT10RF digistat  Worcester Part No. 7 716 192 052	DT10RF optimiser*  Worcester Part No. 7 716 192 053	RT10 room thermostat*#  Worcester Part No. 7 719 002 505	TD200 text display*  Worcester Part No. 7 719 002 506
FR10 intelligent room thermostat^†  Worcester Part No. 7 716 192 065	FR110 programmable room thermostat†  Worcester Part No. 7 716 192 066	FW100 weather compensation controller†  Worcester Part No. 7 716 192 067	RS telescopic flue kit (100mm dia.)  Worcester Part No. 7 716 191 082
Long telescopic flue kit (100mm dia.)  Worcester Part No. 7 716 191 171	Standard telescopic horizontal flue kit (125mm dia.)  Worcester Part No. 7 719 003 702	Vertical BF kit (100mm dia.)  Worcester Part No. 7 719 002 430	Vertical BF kit (125mm dia.)  Worcester Part No. 7 719 002 431

Greenstar combi boiler range accessories

<p>1,000mm extension kit (100mm dia.)</p> <p>Worcester Part No. 7 716 191 083</p>	<p>2m flue extension (100mm dia.)</p> <p>Worcester Part No. 7 716 191 172</p>	<p>Short flue extension 220mm (100mm dia.)</p> <p>Worcester Part No. 7 716 191 133</p>	<p>1,000mm extension (125mm dia.)</p> <p>Worcester Part No. 7 719 003 666</p>	<p>Vertical pre-piping assembly for CDi combi</p> <p>Worcester Part No. 7 716 192 607</p>	<p>Earth bonding strip</p> <p>Worcester Part No. 7 716 192 686</p>	<p>Below boiler pipe cover</p> <p>Worcester Part No. 7 716 192 608</p>	<p>Plume management kit (60mm dia.)</p> <p>Worcester Part No. 7 716 191 086</p>
<p>45° bend (100mm dia.)</p> <p>Worcester Part No. 7 716 191 085</p>	<p>45° bend (125mm dia.)</p> <p>Worcester Part No. 7 719 003 665</p>	<p>90° bend (100mm dia.)</p> <p>Worcester Part No. 7 716 191 084</p>	<p>90° bend (125mm dia.)</p> <p>Worcester Part No. 7 719 003 664</p>	<p>Extension (60mm dia., 1,000mm)</p> <p>Worcester Part No. 7 716 191 087</p>	<p>90° bend (60mm dia.)</p> <p>Worcester Part No. 7 716 191 088</p>	<p>45° bend (60mm dia.)</p> <p>Worcester Part No. 7 716 191 089</p>	<p>Flat roof flashing kit (100mm & 125mm dia.)</p> <p>Worcester Part No. 7 716 191 090</p>
<p>High level horizontal flue adaptor (100mm dia.)</p> <p>Worcester Part No. 7 719 002 432</p>	<p>High level horizontal flue adaptor (125mm dia.)</p> <p>Worcester Part No. 7 719 002 433</p>	<p>Support bracket kit (100mm dia.)</p> <p>Worcester Part No. 7 716 191 092</p>	<p>Support bracket kit 6 pack (100mm dia.)</p> <p>Worcester Part No. 7 716 191 173</p>	<p>Pitched roof flashing kit (100mm & 125mm dia.)</p> <p>Worcester Part No. 7 716 191 091</p>	<p>Plume management terminal guard round (60mm dia.)</p> <p>Worcester Part No. 7 716 191 176</p>		
<p>Support bracket kit (125mm dia.)</p> <p>Worcester Part No. 7 716 191 174</p>	<p>Text display wall mounting socket</p> <p>Worcester Part No. 7 719 002 718</p>	<p>Filling link*</p> <p>Worcester Part No. 7 716 192 281</p>	<p>Vertical pre-piping assembly for i Junior & Si</p> <p>Worcester Part No. 7 716 192 570</p>				

The very best training programmes from Worcester



Worcester has always placed great emphasis on technical support and training for installers and service engineers. Today this need is greater than ever. The differences between a combi, regular and system boiler are substantial, and the technology of each continues to advance at a rapid pace.

With the increase of renewables technologies in the UK, the need for training has never been greater.

To ensure the highest levels of competence and expertise in the installation of all Worcester products, the company runs intensive training courses for installers, commissioning engineers and operatives involved with servicing and fault finding.

Courses available

Our training facilities offer a number of courses suitable for the installer and commissioning engineers, and a more in-depth course for the servicing and fault finding engineers.



Training lab at West Thurrock Academy

Training Centres throughout the UK

Worcester's network of regional training venues is strategically located across the country and includes our state-of-the-art Academy at the Company Headquarters in Worcester. This facility has recently been upgraded to include a heat pump training lab, showcasing our range of ground and air source heat pumps.

Further academies are located at West Thurrock in Essex, Bradford, Clay Cross in Derbyshire and Bangor in Northern Ireland, all offering our full suite of courses. Please phone 01905 752526 for more information about a course near you. Each course is run by specialist trainers and is superbly equipped to deliver a combination of classroom theory and practical hands-on experience that's second to none.

College-linked Learning

As well as offering training at our own centres, Worcester has established close partnerships with many colleges around the UK, equipping them with our latest products. Call us on 01905 752526 to find out when we will be running the course of your choice at a college in your area.

Mobile training

To complement our training venues across the country, we can also bring training to you.

We have mobile vehicles fully equipped with operational Greenstar gas-fired boilers, dry strip-down models and even a Greensource Air to Air Heat Pump, ensuring that quality training in a comfortable environment can be achieved on your doorstep!

If it's oil training you require, our 7.5 tonne mobile oil vehicle is available throughout the country for hands-on product training and OFTEC assessments.

Distance Learning/Web Based Learning

Worcester has produced a selection of Distance Learning CD ROMs/DVDs which are packed with information. Call 0844 892 9800 for your copies, or visit www.worcester-bosch.co.uk for information on Web Based Learning.

Get on course for a more profitable future now.

Call now for more information 01905 752526



www.worcester-bosch.co.uk

Worcester training courses



One stop shop training

We are here to provide you with training and assistance for all areas of your business, not just product training. IT Skills and Sales & Marketing are just 2 of the courses we now offer to help your business grow. Call us on 01905 752526 to order a full training course portfolio.

Worcester training courses	
Greenstar CDi gas-fired condensing combi boilers	
Models covered	Greenstar 27/30/37/42CDi
Duration	1 day
Greenstar i Junior & Si gas-fired condensing combi boilers	
Models covered	Greenstar 24/28i Junior Greenstar 25/30Si
Duration	1 day
Greenstar Highflow CDi & FS CDi regular floor standing gas-fired condensing combi and regular boilers	
Models covered	Greenstar Highflow 440/550CDi Greenstar FS 30/42CDi Regular
Duration	1 day
Greenstar system & regular gas-fired condensing boilers	
Models covered	Greenstar 12/15/18/24Ri Greenstar 30/40CDi Regular Greenstar FS 30/42CDi Regular Greenstar 30CDi System Greenstar 12/15/18/24i System
Duration	1 day
Greenstar controls	
Models covered	MT10/MT10RF/DT20RF/DT20/DT10RF/TD200/RT10/ FR10/FR110/FW100/ISM1
Duration	1 day
Greenstar Danesmoor, Heatslave & Camray high efficiency condensing oil-fired boilers – pre-OFTEC training	
Models covered	Greenstar Danesmoor series Greenstar Heatslave series Greenstar Camray series
Duration	1 day
Greenskies solar system	
Covering	Installation, Commissioning and Servicing
Duration	2 days
Greenstore ground source heat pumps	
Covering	Installation, Commissioning and System Design
Duration	2 days
Greensource heat pumps – air to water	
Covering	Installation, Commissioning and System Design
Duration	2 days
Greensource heat pumps – air to air	
Covering	Installation, Commissioning and System Design
Duration	1 day
BPEC warm water underfloor heating installation course	
Covering	Product overview, basic principles & advantages of underfloor heating, floor systems and finishes, operation, installation, testing, post installation activities
Duration	2 days

OFTEC ASSESSMENT	
OFTEC 101	
Covering	Domestic/Light Commercial Pressure Jet Commissioning and Servicing
Duration	3 day course
OFTEC 105e	
Covering	Domestic/Light Commercial Pressure Jet Boiler Installation
Duration	1 day assessment
OFTEC 101 & 105e	
Covering	Domestic/Light Commercial Pressure Jet Installation, Commissioning and Servicing
Duration	3 day course
OFTEC 600a	
Covering	Oil Tank Installation and Associated Controls
Duration	1 day assessment course
OFTEC 101/105e/600e	
Covering	Domestic/Light Commercial Pressure Jet Boiler Installation, Commissioning, Servicing and Oil Tank Installation and Associated Controls
Duration	4 days
Mobile OFTEC	
All above covered throughout the country on the mobile training vehicle as well as in all our centres.	
Unvented cylinder course	
Covering	All G3 Regulations for the Installation, Servicing and Commissioning of Unvented Cylinders. This course is certified by Logic Certification.
Duration	1 day
Chemical water treatment	
Covering	Water treatment of domestic heating systems in accordance with BS 7593: 2006
Duration	1 day
Construction skills F-Gas training/assessment certification	
Covering	Qualifies for Construction Skills Certification & Registration (valid for 5 years) and Voluntary ACRIB Registration
Duration	4 days



NB: Please note to attend OFTEC courses you must have a minimum of 12 months' experience installing/servicing oil boilers. For inexperienced candidates, our Greenstar Danesmoor, Heatslave and Camray course offers pre-OFTEC training. For experienced oil technicians training is not a pre-requisite for OFTEC assessment.

A complete after-sales service

Notes

As part of the worldwide Bosch Group, Worcester strives to maintain the highest possible standards of after-sales care.

In addition to the no-nonsense parts and labour warranty applicable to all Worcester boilers, you and your customers have the assurance that every Worcester boiler is manufactured to both the appropriate British and European standards.

Worcester Contact Centre

Should you require support, our fully trained Contact Centre staff, based at our head office in Worcester, are ready to take your calls. Whatever your query our contact centre operators along with our nationwide team of engineers are ready to help you.

Boiler Protection Options

Worcester offers boiler protection including service and maintenance contracts. Please call the Worcester Contact Centre for further details.

If you do not offer annual service and maintenance contracts please refer your customers to the Worcester Contact Centre:

Tel: 08457 256 206

Fax: 01905 757 536

Opening Times

Monday – Friday: 7.00am – 8.00pm

Saturday: 8.00am – 5.00pm

Sunday: 9.00am – 12 noon

All the technical advice you need

Spares

Genuine replacement parts for all supported Worcester boilers are readily available from stock, on a next day delivery basis. For more information please call your local stockist. You can find a spares stockist on our website.

Customer Technical Support

The Worcester Technical Helpline is a dedicated phone line – committed to providing a comprehensive service to complement the brand name and quality of our products. Our experienced team of technical experts provides answers to queries of a technical nature across the entire Worcester range.

Worcester also has a pre-sales department, which provides assistance in selecting a boiler system to suit a particular application, along with full guidance on installation. For more information please contact the Technical Helpline or alternatively visit our website where literature can be downloaded at www.worcester-bosch.co.uk

Technical

Tel: 0844 892 3366

Fax: 01905 752 741

Opening Times

Monday – Friday: 7.00am – 8.00pm

Saturday: 8.30am – 4.00pm



Useful numbers

Sales

Tel: 01905 752640
Fax: 01905 456445

Spare Parts

Tel: 01905 752576
Fax: 01905 754620

Technical Helpline (Pre & Post Sales)

Tel: 0844 892 3366
Fax: 01905 752741

Renewables Technical Helpline

Email: renewable.energy@uk.bosch.com
or telephone 0844 892 4010

Training

Tel: 01905 752526
Fax: 01905 752535

Literature

Email: literature@uk.bosch.com
or download instantly from our website
or telephone 0844 892 9800

Customer Service

Engineer Appointments

Email: appointment.worcester@uk.bosch.com
or telephone 0844 892 3000

Enquiries

Email: service.mailbox@uk.bosch.com
or telephone 0844 892 3000

Guarantee Registration

To register your Worcester guarantee,
please visit our website or
telephone 0844 892 2552

Calls to the listed 0844 numbers are charged at up to 3 pence per minute from BT land lines.
Calls from mobiles and some other networks may vary. Calls to and from Bosch Thermotechnology Ltd
may be recorded for training and quality assurance purposes.

www.worcester-bosch.co.uk



Worcester, Bosch Group is a brand name of Bosch Thermotechnology Ltd.

This leaflet is accurate at the date of printing, but may be superseded and should be disregarded if specification and/or appearances are changed in the interest of continued improvement. The statutory rights of the consumer are not affected.

Part No. 8 716 115 773 C 11/10



Worcester, Bosch Group,
Cotswold Way, Warndon,
Worcester, WR4 9SW